



Paddle Wheel Flow Meter



FineTek Flow Lab



FineTek is the company who owns a Second Class flow test laboratory in Taiwan. With the most professional R&D team, FineTek develops various high precision flow meters and related parts. Moreover, FineTek is certificated and constantly validated by First Class accreditation organization, the Flow Laboratory of the National Measurement Laboratory, R.O.C (Center for Measurement Standards, ITRI), which is approved to guarantee the accuracy on the flow measurement in each delivery. The TAF flow laboratory of FineTek has been certificated and approved by Taiwan Accreditation Foundation (TAF) and conforms to the regulations of international organizations such as ILAC and APALC. It has the complete ability to conduct uncertainty testing and rating for flow test.

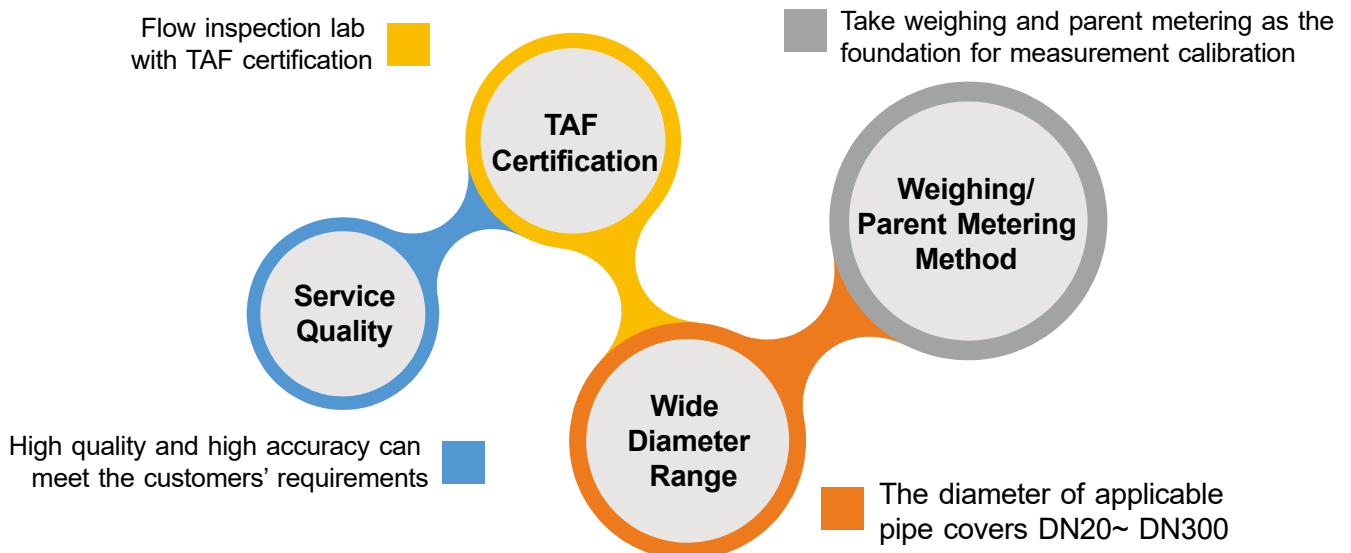

EPR PADDLE WHEEL FLOW METER

WORKING PRINCIPLE

The Paddle Wheel Flow Meter measures the flow velocity by using the fluidic to drive the blade rotation, and calculates the flow rate based on the flow velocity. ERP1 series flow meter consists of flow transmitter and pipe fitting. The light and compact design allows the user to carry, install and operate it conveniently.

The product is calibrated by professional flow test device, with the accuracy of K value reaching $\pm 3\%$.

The measuring range is 0.3 ~10m/s, with high linearity. Display and non-display type are both available.

The display type is built-in with accumulated flow storage device.

FEATURES

- Controlled by a microprocessor, with convenient operation and comprehensive functions.
- Power supply: 12-36 Vdc.
- Analog output: 4-20mA with 10% higher range as 4-21.6mA
- Simulated test output: 0-24 mA.
- Pulse output: Optical-coupling transistor output.
- Simulated frequency output: 0-300Hz
- Pure sensing non-display type is for convenient system integration
- LCM (Graphic 128x64 Dots) display type
- Built-in FRAM (Ferroelectric Random Access Memory) flash memory
- Easily separated from the sensor.
- LED indicator displays the alarm status.
- Upper limit settings of the analog output.
- Analog output flow rate and velocity filter settings.
- LED shows three back-lit modes, ON/OFF/In Operation.
- With RS485 communication.
- Parameter settings (K factor, pipe diameter, device ID, baudrate).
- Supports Traditional Chinese, Simplified Chinese, English, etc.

APPLICATIONS

The Paddle Wheel Flow Meter is applicable to neutral or corrosive liquids that are non-granular or non-viscous. It connects with an analog output and pulse output signal to form a monitoring system, which can display instantaneous flow and accumulated flow. Moreover, it can form a control circuit to adjust the valve or operate the switch.

The detected medium must not contain any iron filings, particles which will attached the rotary paddle wheel and affect the accuracy and also cause damage. If there is possibility to have iron filings, particles in the process or pump operation, please install the magnet screen filters (please consider the Pressure loss) on upstream side for the minimum distance 15 times of pipe diameter.

- Food industry
- Beverage industry
- Water treatment industry
- Pharmaceutical industry
- Dyeing industry
- Chemical industry
- Semi-conductor industry
- PCB wet process control

STANDARD SPECIFICATIONS

PVC Pipe material & PP Blade

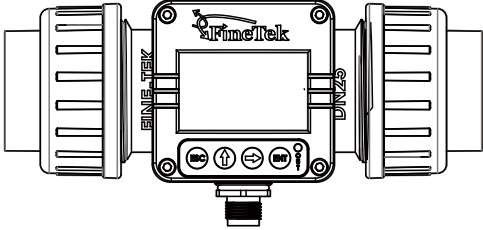
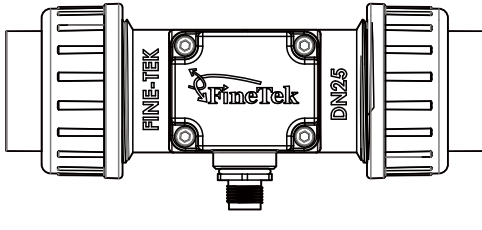
Model Type				
Specification	Intelligent All-in-one model	Flow transmitter model	Pulse output model	
Applicable pipe diameter	DN15 · DN20 · DN25 · DN40 · DN50			
Pipe material	PVC			
Flow velocity range	0.3~10m/s			
Accuracy	Under standard K Factor $\pm 3\%$ F.S. (Flow velocity 6~10m/s reach $\pm 0.5\%$)			
Repeatability	$\pm 0.4\%$			
Measuring principle	Magnetic			
Viscosity range	300 cSt, max.			
Impurity range	Must be nonmagnetic 1%, max.(Size of particles 0.5mm max.)			
Process temp.	$-15^{\circ}\text{C}\sim 60^{\circ}\text{C}(5^{\circ}\text{F}\sim 140^{\circ}\text{F})$			
Ambient humidity	$<80\%$, non-condensing			
Installation method	Transmitter + T-fitting			
Process pressure	10-bar, Max.			
IP rating	IP66, the connector shall be inserted and fastened			
Analog output	4~20mA		N/A	
Impedance	1300W, at 36Vdc 1000W, at 30Vdc 700W, at 24Vdc 450W, at 18Vdc 200W, at 12Vdc			
Pulse output	NPN, PNP 200mA overcurrent protection			
Frequency range	0~300Hz		N/A	
Display	LCM, 128*64, Backlit		N/A	
Power supply voltage	12~36Vdc, $\pm 10\%$			
Power consumption	$<1.5\text{VA}$			
Reverse protection of power supply	YES			
Communication port	RS485, Modbus		N/A	
Accumulated flow storage device	16K, FRAM		NO	

STANDARD SPECIFICATIONS

PP Pipe material & PP Blade

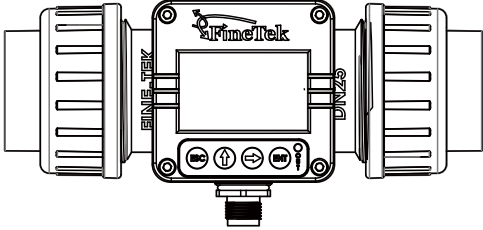
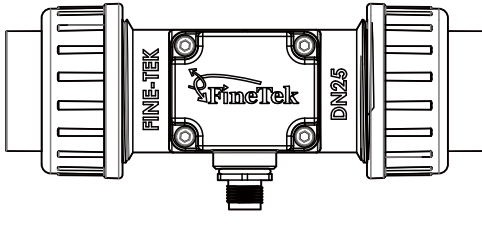
Model Type				
Specification	Intelligent All-in-one model	Flow transmitter model	Pulse output model	
Applicable pipe diameter	DN20 · DN25 · DN40			
Pipe material	PP			
Flow velocity range	0.3~10m/s			
Accuracy	Under standard K Factor $\pm 3\%$ F.S. (Flow velocity 6~10m/s reach $\pm 0.5\%$)			
Repeatability	$\pm 0.4\%$			
Measuring principle	Magnetic			
Viscosity range	300 cSt, max.			
Impurity range	Must be nonmagnetic 1%, max.(Size of particles 0.5mm max.)			
Process temp.	$-15^{\circ}\text{C}\sim 60^{\circ}\text{C}(5^{\circ}\text{F}\sim 140^{\circ}\text{F})$			
Ambient humidity	$<80\%$, non-condensing			
Installation method	Transmitter + T-fitting			
Process pressure	10-bar, Max.			
IP rating	IP66, the connector shall be inserted and fastened			
Analog output	4~20mA		N/A	
Impedance	1300W, at 36Vdc 1000W, at 30Vdc 700W, at 24Vdc 450W, at 18Vdc 200W, at 12Vdc			
Pulse output	NPN, PNP 200mA overcurrent protection			
Frequency range	0~300Hz		N/A	
Display	LCM, 128*64, Backlit		N/A	
Power supply voltage	12~36Vdc, $\pm 10\%$			
Power consumption	$<1.5\text{VA}$			
Reverse protection of power supply	YES			
Communication port	RS485, Modbus		N/A	
Accumulated flow storage device	16K, FRAM		NO	

STANDARD SPECIFICATIONS

SUS Pipe material & PVDF Blade

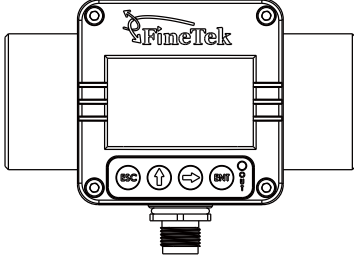
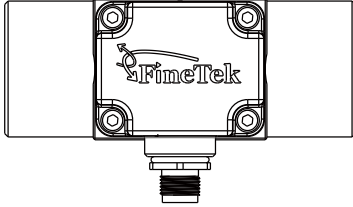
Model Type				
Specification	Intelligent All-in-one model	Flow transmitter model	Pulse output model	
Applicable pipe diameter	DN20、DN25、DN40、DN50			
Pipe material	SUS304、SUS316、SUS316L			
Flow velocity range	0.3~10m/s			
Accuracy	Under standard K Factor $\pm 3\%$ F.S. (Flow velocity 6~10m/s reach $\pm 0.5\%$)			
Repeatability	$\pm 0.4\%$			
Measuring principle	Magnetic			
Viscosity range	300 cSt, max.			
Impurity range	Must be nonmagnetic 1%, max.(Size of particles 0.5mm max.)			
Process temp.	$-15^{\circ}\text{C}\sim 100^{\circ}\text{C}$ ($5^{\circ}\text{F}\sim 212^{\circ}\text{F}$)			
Ambient humidity	<80%, non-condensing			
Installation method	Transmitter +T-fitting			
Process pressure	10-bar, Max.			
IP rating	IP66, the connector shall be inserted and fastened			
Analog output	4~20mA		N/A	
Impedance	1300W, at 36Vdc 1000W, at 30Vdc 700W, at 24Vdc 450W, at 18Vdc 200W, at 12Vdc			
Pulse output	NPN, PNP 200mA overcurrent protection			
Frequency range	0~300Hz		N/A	
Display	LCM,128*64,Backlit		N/A	
Power supply voltage	12~36Vdc, $\pm 10\%$			
Power consumption	<1.5VA			
Reverse protection of power supply	YES			
Communication port	RS485,Modbus		N/A	
Accumulated flow storage device	16K,FRAM		NO	

STANDARD SPECIFICATIONS

SUS Pipe material & SUS316 Blade

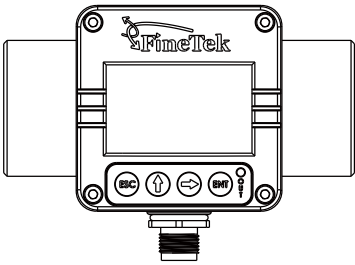
Model Type	
Specification	Intelligent All-in-one model
Applicable pipe diameter	DN20、DN25、DN40、DN50
Pipe material	SUS304、SUS316、SUS316L
Flow velocity range	0.5~8 m/s
Accuracy	Under standard K Factor $\pm 3\%$ F.S.
Repeatability	$\pm 0.4\%$
Measuring principle	Magnetic
Viscosity range	300 cSt, max.
Impurity range	Must be nonmagnetic 1%, max. (Size of particles 0.5mm max.)
Process temp.	-15°C~100°C (5°F~212°F)
Ambient humidity	<80%, non-condensing
Installation method	Transmitter +T-fitting
Process pressure	10-bar,Max.
IP rating	IP66, the connector shall be inserted and fastened
Analog output	4~20mA
impedance	1300W, at 36Vdc 1000W, at 30Vdc 700W, at 24Vdc 450W, at 18Vdc 200W, at 12Vdc
Pulse output	NPN□PNP 200mA overcurrent protection
Frequency range	0~300Hz
Display	LCM,128*64,Backlit
Power supply voltage	12~36Vdc, $\pm 10\%$
Power consumption	<1.5VA
Reverse protection of power supply	YES
Communication port	RS485,Modbus
Accumulated flow storage device	16K,FRAM

DIMENSIONS

INTELLIGENT ALL-IN-ONE MODEL

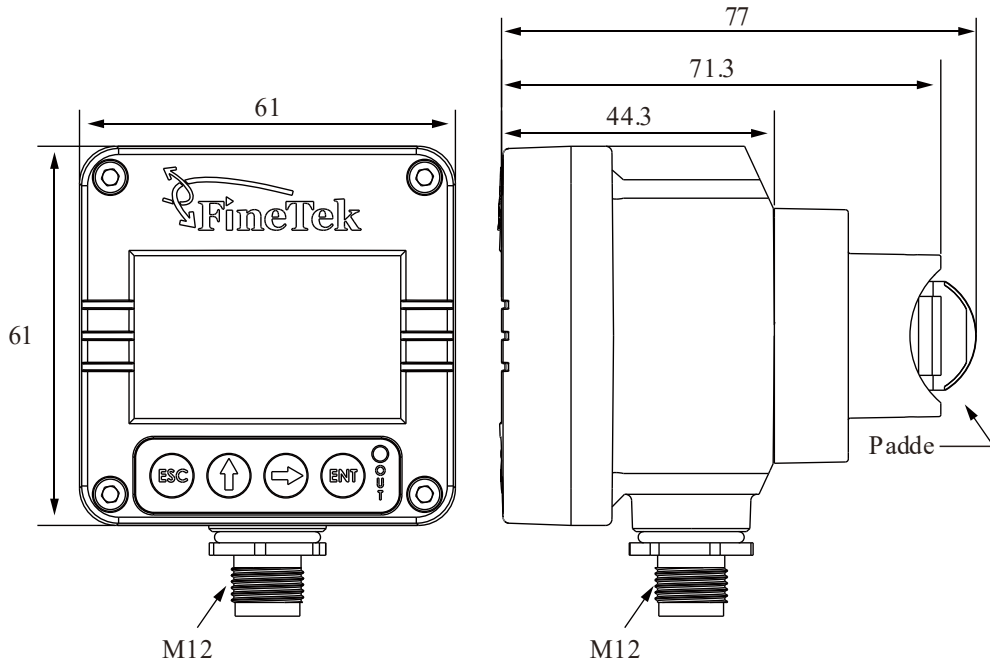

FLOW TRANSMITTER MODEL & PULSE OUTPUT MODEL

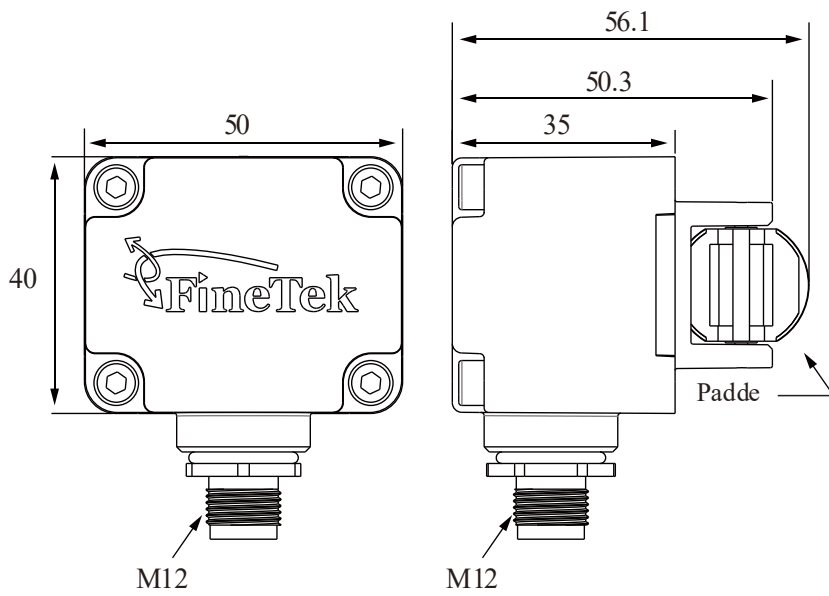

DIMENSIONS

INTELLIGENT ALL-IN-ONE MODEL (ENGINEERING PLASTICS)

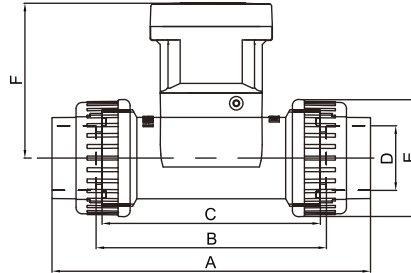

Diameter-DN (mm)	Pipe standards	A (mm)	B (mm)	C (mm)	D (mm)	E (mm)	F (mm)
15	DIN/ISO ASTM JIS CNS 4053-1	128	96	90	20 21.3 18.4 22	43	79.1
20	DIN/ISO ASTM JIS CNS 4053-1	144	106	100	25 26.7 26.45 26	53	76.3
25	DIN/ISO ASTM JIS CNS 4053-1	159	115	109	32 33.4 32.55 32	58	77
40	DIN/ISO ASTM JIS CNS 4053-1	189	125	119	50 48.3 48.7 48	83	83.9
50	DIN/ISO ASTM JIS CNS 4053-1	216	140	130	63 60.3 60.8 60	103	90

INTELLIGENT ALL-IN-ONE MODEL (STAINLESS STEEL)

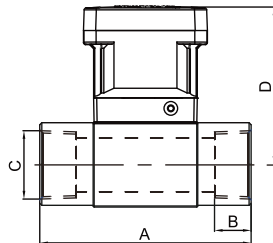

Diameter-DN (mm)	A (mm)	B (mm)	C (mm)	D (mm)
20	94	17 18.3 18.3	PF 3/4" PT 3/4" NPT 3/4"	77
25	104	23 18 18	PF 1" PT 1" NPT 1"	77
40	129	23 22 22	PF 1-1/2" PT 1-1/2" NPT 1-1/2"	83.4
50	148.5	27.5 24 24	PF 2" PT 2" NPT 2"	90

DIMENSIONS

FLOW TRANSMITTER MODEL & PULSE OUTPUT MODEL (ENGINEERING PLASTICS)

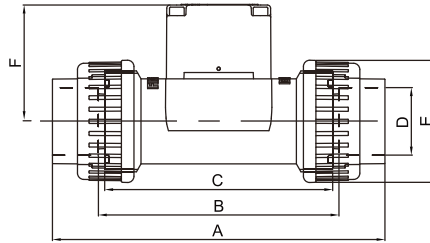

Diameter-DN (mm)	Pipe standards	A (mm)	B (mm)	C (mm)	D (mm)	E (mm)	F (mm)
15	DIN/ISO ASTM JIS CNS 4053-1	128	96	90	20 21.3 18.4 22	43	48.4
20	DIN/ISO ASTM JIS CNS 4053-1	144	106	100	25 26.7 26.45 26	53	54.8
25	DIN/ISO ASTM JIS CNS 4053-1	159	115	109	32 33.4 32.55 32	58	55.2
40	DIN/ISO ASTM JIS CNS 4053-1	189	125	119	50 48.3 48.7 48	83	62
50	DIN/ISO ASTM JIS CNS 4053-1	216	140	130	63 60.3 60.8 60	103	68.5

FLOW TRANSMITTER MODEL & PULSE OUTPUT MODEL (STAINLESS STEEL)

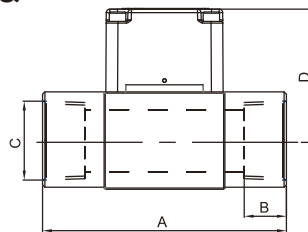

Diameter-DN (mm)	A (mm)	B (mm)	C (mm)	D (mm)
20	94	17 18.3 18.3	PF 3/4" PT 3/4" NPT 3/4"	55
25	104	23 18 18	PF 1" PT 1" NPT 1"	55.6
40	129	23 22 22	PF 1-1/2" PT 1-1/2" NPT 1-1/2"	62
50	148.5	27.5 24 24	PF 2" PT 2" NPT 2"	69

DIMENSIONS

T-FITTING(ENGINEERING PLASTICS)

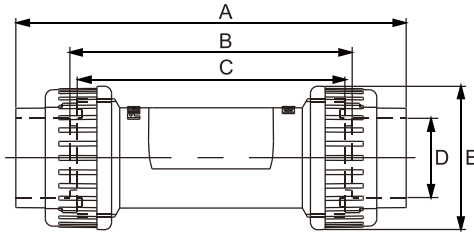

Diameter-DN (mm)	Pipe standards	A (mm)	B (mm)	C (mm)	D (mm)	E (mm)
15	DIN/ISO ASTM JIS CNS 4053-1	128	96	90	20 21.3 18.4 22	43
20	DIN/ISO ASTM JIS CNS 4053-1	144	106	100	25 26.7 26.45 26	53
25	DIN/ISO ASTM JIS CNS 4053-1	159	115	109	32 33.4 32.55 32	58
40	DIN/ISO ASTM JIS CNS 4053-1	189	125	119	50 48.3 48.7 48	83
50	DIN/ISO ASTM JIS CNS 4053-1	216	140	130	63 60.3 60.8 60	103

T-FITTING (STAINLESS STEEL)

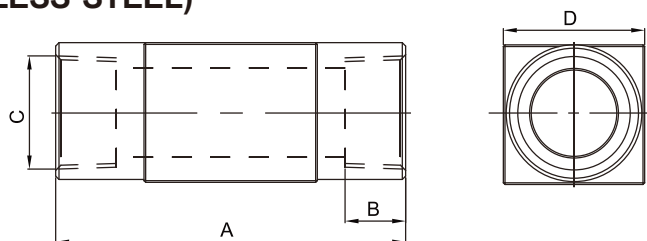

Diameter-DN (mm)	A (mm)	B (mm)	C (mm)	D (mm)
20	94	17 18.3 18.3	PF 3/4" PT 3/4" NPT 3/4"	42
25	104	23 18 18	PF 1" PT 1" NPT 1"	55.6
40	129	23 22 22	PF 1-1/2" PT 1-1/2" NPT 1-1/2"	62
50	148.5	27.5 24 24	PF 2" PT 2" NPT 2"	72

CONTROL SYSTEM DIAGRAM

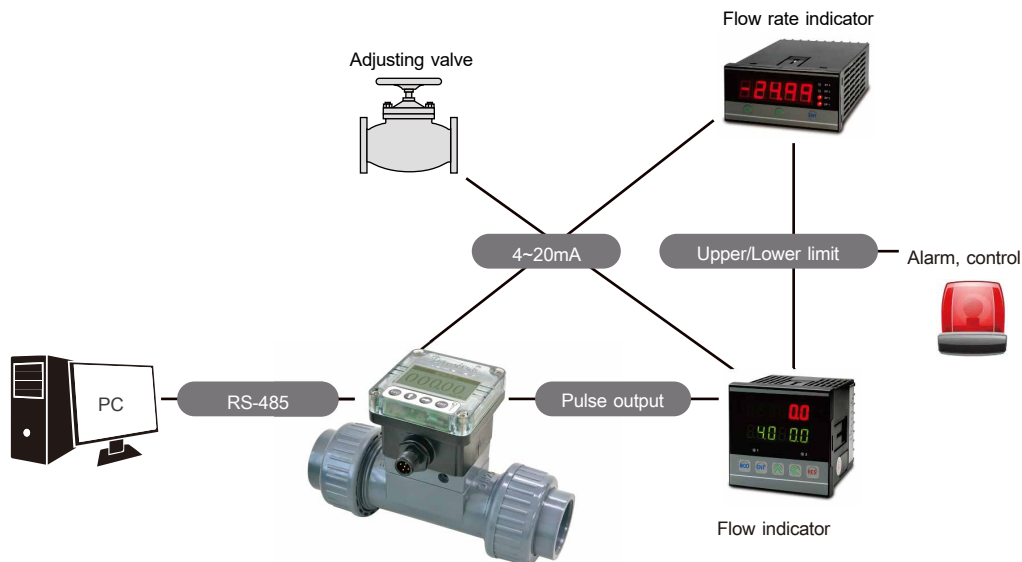

SELECTING FLOW AND PIPE DIAMETER

Plastic Blade

Material	Pipe diameter (mm)	Flow Range (m ³ /h)	
		Flow velocity 0.3m/s (min)	Flow velocity 10m/s (max)
PVC Pipe material & PP Blade	15	0.19	6.36
	20	0.34	11.31
	25	0.53	17.67
	40	1.35	45.23
	50	2.12	70.68
PP Pipe material & PP Blade	20	0.34	11.31
	25	0.53	17.67
	40	1.35	45.23
SUS Pipe material & PVDF Blade	20	0.34	11.31
	25	0.53	17.67
	40	1.35	45.23
	50	2.12	70.68

Stainless Blade

Material	Pipe diameter (mm)	Flow Range (m ³ /h)	
		Flow velocity 0.5m/s (min)	Flow velocity 8m/s (max)
SUS Pipe material & SUS316 Blade	20	0.57	9.04
	25	0.89	14.13
	40	2.27	36.18
	50	3.54	56.54

RELATIONSHIP BETWEEN K VALUE AND FITTING DIAMETER:

Intelligent All-in-One Model

Material	Connection & Standard Type	K Factor (Pulse/Liter)				
		DN15	DN20	DN25	DN40	DN50
PVC Pipe material & PP Blade	DIN/ISO	101	73.5	50	17	9.5
	ASTM	101	73.5	50	17	9.5
	JIS	101	73.5	50	17	9.5
	CNS 4053-1	101	73.5	50	17	9.5
PP Pipe material & PP Blade	DIN/ISO	---	73.5	49	---	---
	ASTM	---	73.5	49	---	---
	JIS	---	73.5	49	---	---
	CNS 4053-1	---	73.5	49	---	---
SUS Pipe material & PVDF Blade	Thread PF	101	73.5	50	17	9.5
	Thread PT	101	73.5	50	17	9.5
	Thread NPT	101	73.5	50	17	9.5
SUS Pipe material & SUS316 Blade	Thread PF	---	66	49	16	9.4
	Thread PT	---	66	49	16	9.4
	Thread NPT	---	66	49	16	9.4

※ US: GL (Gallon) K factor = Pulse/Liter × 3.785; UK: GL (Gallon) K factor = Pulse/Liter × 4.546.

Flow transmitter type & Pulse Output type

Material	Connection & Standard Type	K Factor (Pulse/Liter)				
		DN15	DN20	DN25	DN40	DN50
PVC Pipe material & PP Blade	DIN/ISO	95	60	27.5	8.3	5.92
	ASTM	95	60	27.5	8.3	5.92
	JIS	95	60	27.5	8.3	5.92
	CNS 4053-1	95	60	27.5	8.3	5.92
SUS Pipe material & PVDF Blade	Thread PF	---	60	27.5	8.3	5.6
	Thread PT	---	60	27.5	8.3	5.6
	Thread NPT	---	60	27.5	8.3	5.6

※ US: GL (Gallon) K factor = Pulse/Liter × 3.785; UK: GL (Gallon) K factor = Pulse/Liter × 4.546.

TRANSMITTER INSTALLATION

INTELLIGENT ALL-IN-ONE MODEL

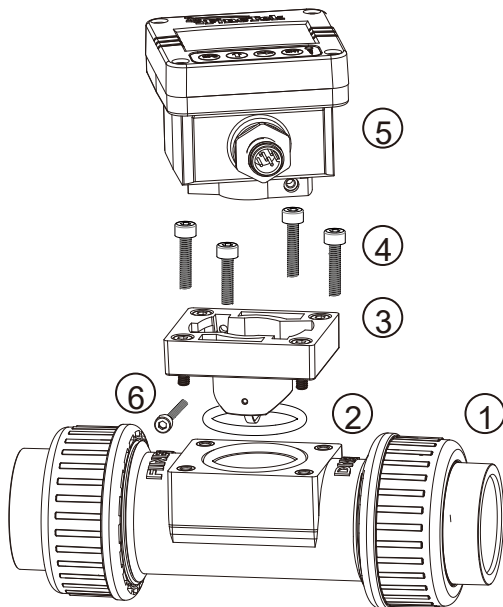

Installation steps

1. T-fitting of flow meter.
2. Place the O-shaped ring in the sealing tank, and unfold it naturally.
3. Make the blade holder face downward and go through the hole and O-shaped ring. Level and align it.
4. Fasten and align the 4 screws evenly with the
*Fastening torque:
Plastic Blade = 8~10kgf-cm(0.784~0.98N.m)
Stainless Blade = 10~12kgf-cm(0.98~1.176N.m)
5. Point the M12 connector of the display towards you, and insert it into the slot. Level it horizontally and rotate it clockwise to the edge for alignment.
6. Fasten the 2 fixing screws.
*Fastening torque=6~8kgf-cm(0.588~0.784N.m)

*Note: The above steps are for whole machine installation. To install the header only, please perform steps 5~6. Please apply the fastening torque on the screws as required.

FLOW TRANSMITTER MODEL & PULSE OUTPUT MODEL

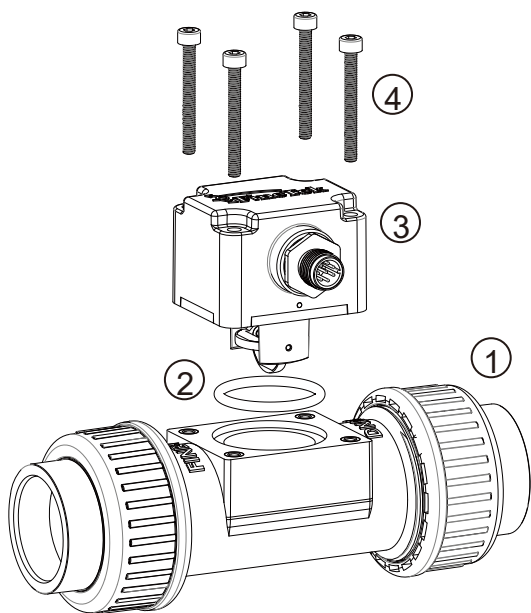

Installation steps

1. T-fitting of flow meter.
2. Place the O-shaped ring in the sealing tank, and unfold it naturally.
3. Make the blade of the transmitter face downward and go through the hole and O-shaped ring. Level and align it.
4. Fasten and align the 4 screws evenly.
*Fastening torque:
Plastic Blade = 8~10kgf-cm(0.784~0.98N.m)
Stainless Blade = 10~12kgf-cm(0.98~1.176N.m)

*Note: Please apply the fastening torque on the screws as required.

M12 CONNECTOR

Connector socket

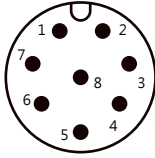

Plug

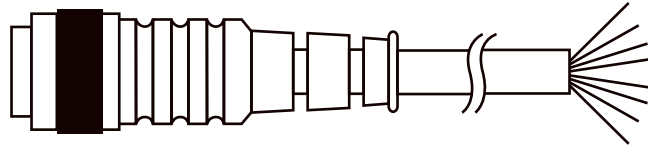

Cable

M12 Socket Pin No.	Function	Cable Color
1	Communication output RS485 -	Black
2	Pulse output Pulse -	Yellow
3	Power supply input DC 0V -	Blue
4	Pulse output Pulse +	Orange
5	Communication output RS485 +	Green
6	Analog output 4~20mA -	Purple
7	Analog output 4~20mA +	Red
8	Power supply input DC12~36V +	Brown

WIRING

4~20mA output

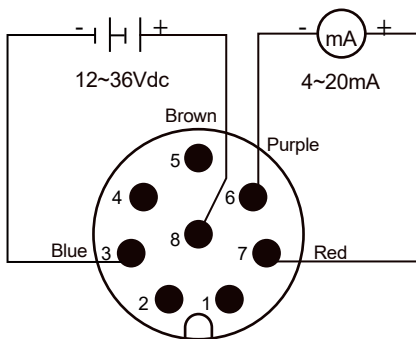

Communication output RS-485

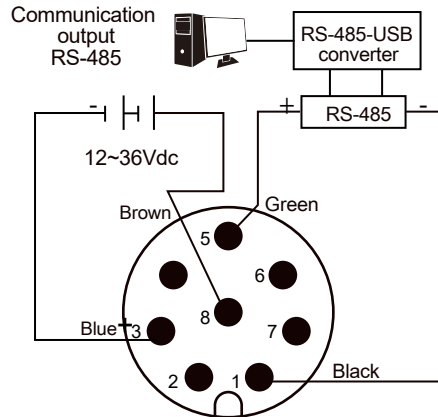

Pulse output NPN

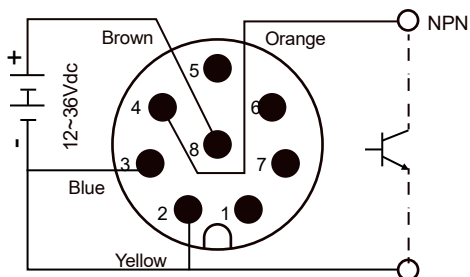

Pulse output PNP

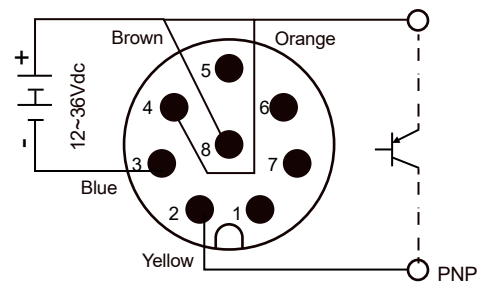

REQUIREMENTS FOR STRAIGHT PIPE SECTION

The straight pipe must be long enough on the upstream side and downstream side where the flow meter is installed. This can obtain an evenly distributed and stable flow field so as to guarantee the measuring accuracy. When installing the flow meter, please choose optimal distance based on the pipe dimension and field environment. Generally, the longer the section of the straight pipe is, the better. The table below lists the minimum distance based on the times of D(D=pipe diameter).

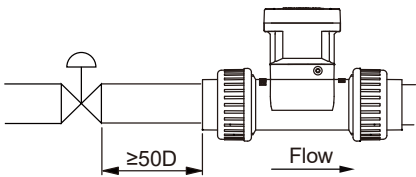
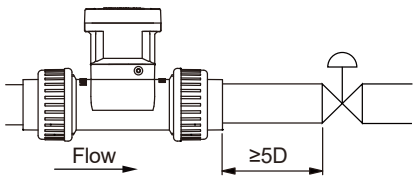
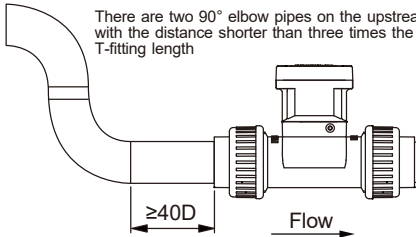
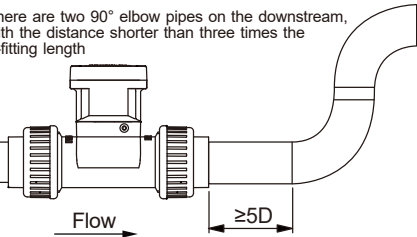
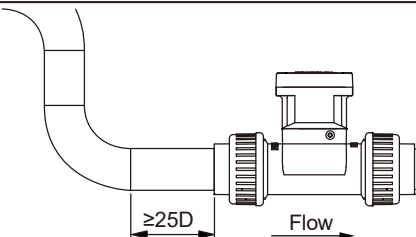
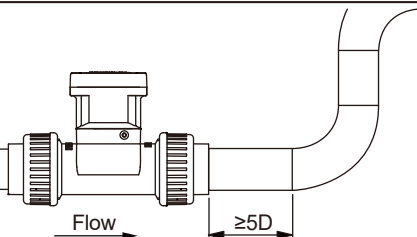
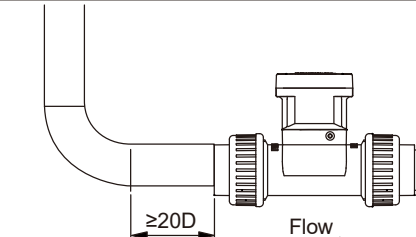
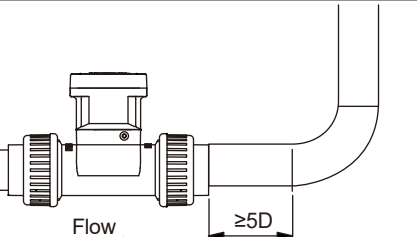
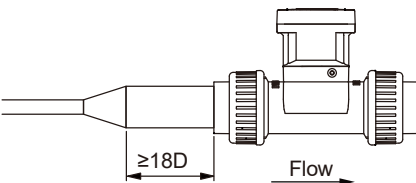
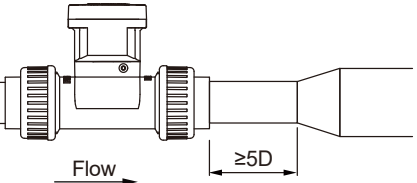
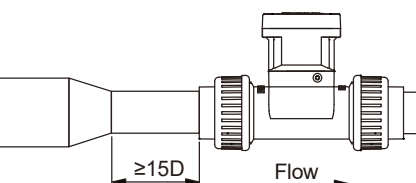
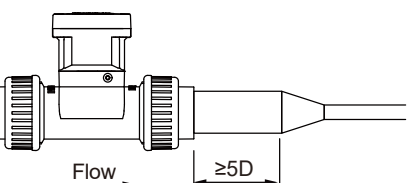
Type	Length of Straight Pipe on the Upstream Side	Length of Straight Pipe on the Downstream Side
Regulating valve		
Keep the two elbow pipes close	<p>There are two 90° elbow pipes on the upstream, with the distance shorter than three times the T-fitting length</p> 	<p>There are two 90° elbow pipes on the downstream, with the distance shorter than three times the T-fitting length</p> 
Dual elbow pipes		
Single elbow pipe		
Diverging pipe		
Convergin pipe		

INSTALLATION REQUIREMENTS

1. The flow meter must be in horizontal or vertical pipe.
2. Ensure the flow meter to keep a full pipe.
3. No air bulb or hole should be generated when getting close to the T-fitting area of the flow meter during the measurement. It will affect the accuracy of the flow measurement.

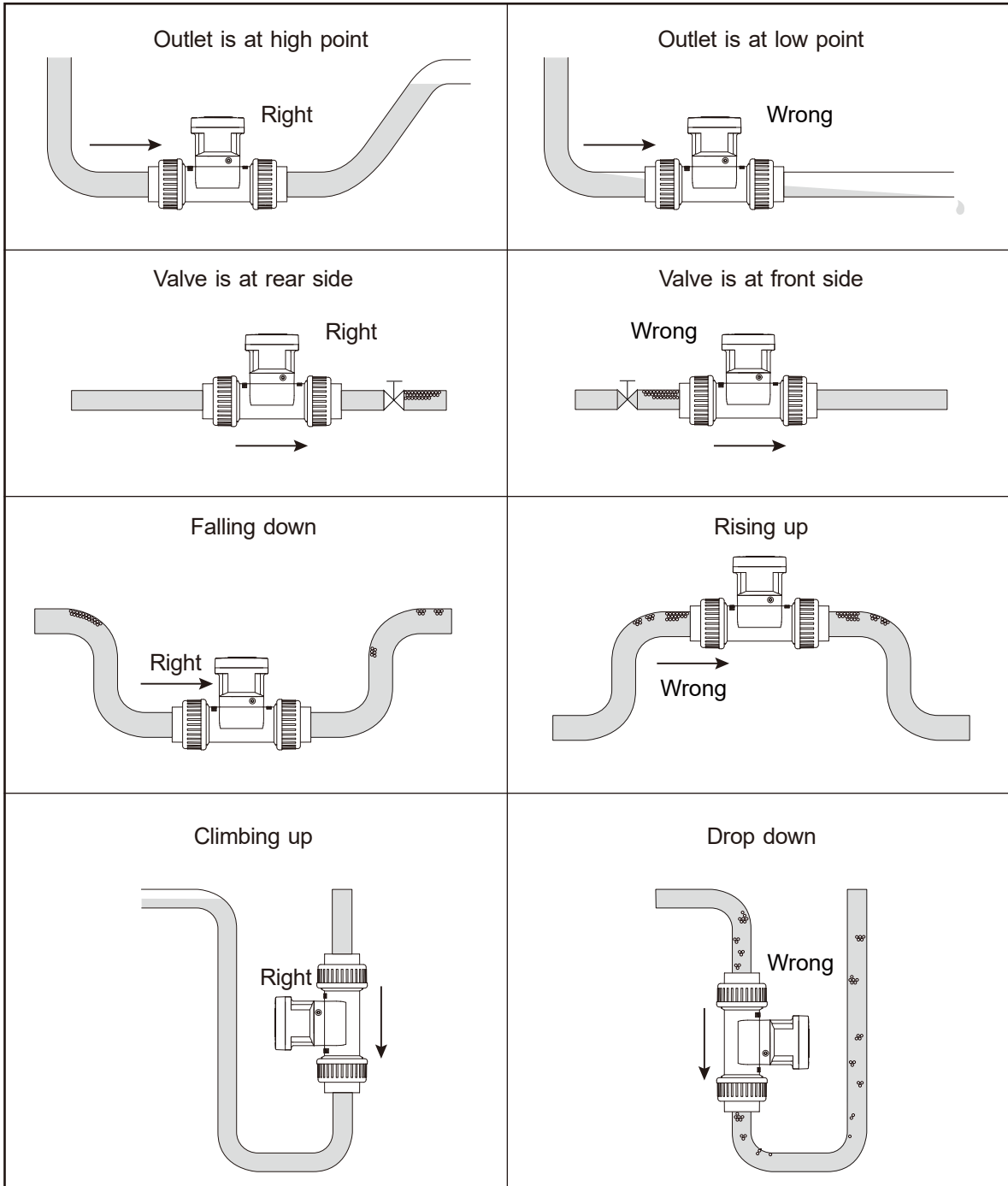

*Note: When installing the flow meter on the horizontal pipe, the sensor blade must face downward. Appropriate material should be selected, and the specifications on pressure and temperature should be followed. Moreover, appropriate pipe diameter should be chosen based on the flow/velocity/diameter.

ORDER INFORMATION

EPR1 0 0 0 0 - ⁰⁹□ ¹⁰□ ¹¹□ ¹²□ ¹³□ ¹⁴□ ¹⁵□ ¹⁶□ ¹⁷□ ¹⁸□ ¹⁹□ ²⁰□ A ²²□

09 10 11 Pipe diameter

- 015: DN15(1/2") (Only available for PP \ PVC)(Pipe material)
- 020: DN20(3/4")
- 025: DN25(1")
- 040: DN40(1-1/2")
- 050: DN50(2")

12 Display model

- A: Without display (Flow transmitter model & Pluse Output model)
- B: LCM display(Intelligent all-in-one madel)

13 14 Pipe material

- MA: SUS 304
- MB: SUS 316
- MC: SUS 316L
- 18: PP
- 23: PVC

15 16 T-fitting standard

(When the pipe material is SUS, please choose "00")

- 00: None
- A A: JIS
- AB: ISO
- AC: ASTM
- AD: DIN
- BA:CNS

} (Only available for PVC \ PP)(Pipe material)

17 18 T-fitting standard connection type

(When the pipe material is PVC \ PP, please choose "00")

- 00: None
- 02: PT female
- 04: PF female
- 08: NPT female

} (Only available for SUS)(Pipe material)

19 20 Blade material

- 18: PP (60°C)
- 24: PVDF (100°C)
- MB: SUS 316 (100°C)(Only available for LCM display)

22 Output

- A: 4~20mA, RS-485, PNP NPN 200mA (Intelligent all-in-one model & Flow transmitter model)
- B: PNP NPN 200mA (Pulse output model)

Global Network

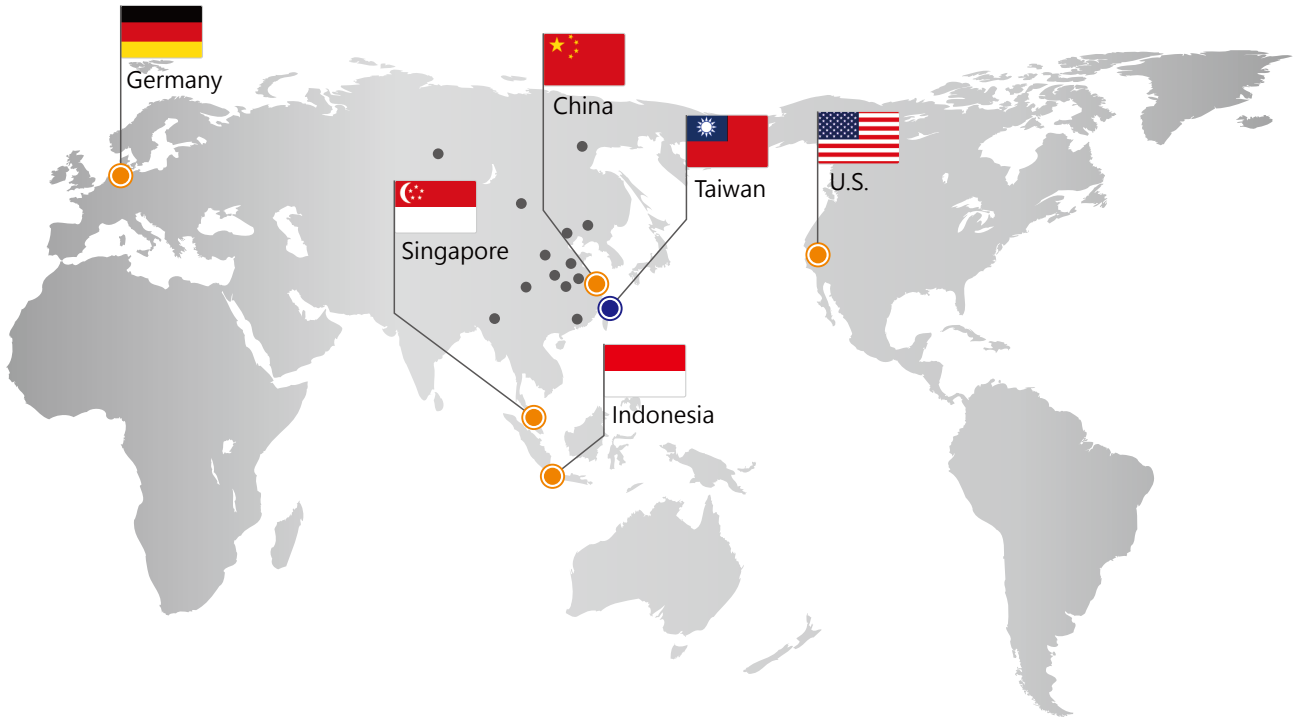

■ Head Quarter

- Taiwan
FineTek Co., Ltd. - Taipei Head Quarter
No.16, Tzuchiang St., Tucheng Industrial Park
New Taipei City 236, Taiwan
TEL: 886-2-2269-6789
FAX: 886-2-2268-6682
EMAIL: info@fine-tek.com

■ North America

- California, U.S.
Aplus Finetek Sensor Inc. - US Office
355 S. Lemon Ave, Suite D
Walnut, CA 91789
TEL: 1 909 598 2488
FAX: 1 909 598 3188
EMAIL: info@aplusfine.com

■ Europe

- Germany
FineTek GmbH - Germany Office
Bei den Kämpen 26
21220 Seevetal-Ramelsloh, Germany
TEL: +49-(0)4185-8083-12
FAX: +49-(0)4185-8083-80
EMAIL: info@fine-tek.de

■ Asia

- China
Fine automation Co., Ltd. - Shanghai Factory
No.451 DuHui Rd, MinHang District, Shanghai,
China 201109
TEL: 86-21-6490-7260
EMAIL: info.sh@fine-tek.com

- Singapore
FineTek Pte Ltd. - Singapore Office
37 Kaki Bukit Place, Level 4 Singapore 416215
TEL: 65-6452-6340
EMAIL: info.sg@fine-tek.com

- Indonesia
PT. FineTek Automation Indonesia - Indonesia Office
PERGUDANGAN TUNAS BITUNG
JL. Raya Serang KM. 13,8, Blok C3 No. 12&15,
Bitung Cikupa, Tangerang 15710
TEL: 62 (021)-2958-1688
EMAIL: info.id@fine-tek.com

- Mütec Instruments GmbH - Germany Office
Bei den Kämpen 26
21220 Seevetal-Ramelsloh, Germany
TEL: +49-(0)4185-8083-0
FAX: +49-(0)4185-8083-80
EMAIL: muetec@muetec.de



Distributor: