



JFR4 FMCW Radar Wave Level Gauge Operation Manual



FineTek Co., Ltd

No.16 Ziqiang St., Tucheng Dist., New Taipei City 23678, Taiwan

Tel : 886-2-22696789

Fax : 886-2-22686682

Website : <http://www.fine-tek.com>

E-mail: info@fine-tek.com

Contents

1. Read Labels	2
2. Product Warranty	3
2.1 New Product Warranty	3
2.2 Repair Warranty	3
2.3 Service Network	4
3. Product Inspection	5
3.1 Item Verification	5
3.2 Safety Inspection.....	5
3.3 Handling & Transportation.....	5
4. Product Introduction	6
4.1 Product introduction	6
4.2 Theory	6
5. Appearance And Dimension	7
6. Installation Instructions	8
6.1 Installation Instructions for JFR481 Radar	8
6.2 Installation Instructions for JFR483 Radar	12
6.3 Installation Instructions for JFR484 Radar	14
6.4 Installation Instructions for JFR485 Radar	17
7. Electrical Connection	20
7.1 Installation Instructions for JFR484 Radar	20
7.2 Cable Installation.....	20
7.3 Cable Shielding and Grounding.....	20
7.4 Cable Shielding and Grounding.....	20
7.5 Safety Instructions.....	21
7.6 Protection Rating.....	21
8. Operating Instructions	22
8.1 Installation Instructions for JFR484 Radar	22
8.2 Button Functions	22
8.3 Button Functions	23
9. Menu Overview	26
10. Transportation and Storage.....	29
11. MODBUS Communication Protocol	29

1. Read Labels

Thank you for purchasing a product from FineTek. This operating manual explains the product's features, working principles, operation, maintenance methods, and usage precautions. It is designed to help users fully understand the correct usage of the product, preventing equipment damage and potential hazards to the operator.

- Before using this product, please read this operating manual thoroughly and carefully.
- If this manual does not meet your needs, please contact our company.
- The contents of this operating manual may vary with version updates and will be uploaded to our company's website for user download.
- Please do not attempt to disassemble or repair the product yourself, as this will void your warranty. Send the product back to our company for repair and calibration or contact us.
- Explanation of warning symbols:



Danger Warning → Indicates the risk of fatal or serious accidents if operated incorrectly



Caution Warning → Indicates that incorrect operation may result in a certain degree of injury and equipment damage.



Electric Shock Warning → Indicates a warning of potential electric shock.



Fire Warning → Indicates a warning of potential fire hazards.



Prohibition Warning → Indicates actions that are prohibited.

2. Product Warranty

2.1 New Product Warranty

- Our products come with a twelve-month warranty from the delivery date. If a failure occurs within this period and meets warranty conditions, there will be no charges for inspection, parts, or repairs.
- If the product has defects due to shipping and not human error, it can be replaced within 7 days by contacting our company.
- When returning a product for repair, please send the complete unit back without disassembling any parts, and ensure it is properly packaged to avoid damage during transit, which could lead to further losses.
- The warranty applies only to customers using the product under normal conditions. It does not cover special applications, abnormal use, or excessive usage.
- The warranty will not apply in the following situations, and charges may be incurred for inspection, parts, and repairs:
 - The product or any parts are beyond the warranty period.
 - Failures or damages resulting from not using the product according to the operating manual or the specified usage environment.
 - Damage caused by force majeure (natural disasters, floods, fires, earthquakes, lightning, typhoons, etc.), human actions (scratches, drops, broken parts, strikes, cracks, heavy impacts, etc.), human negligence (using inappropriate voltage, high humidity, water ingress, stains, corrosion, loss, inadequate storage, etc.), or other abnormal factors. Failures resulting from irresistible external forces due to natural disasters.
 - Damage caused by the customer or a third party installing, adding, expanding, modifying, or repairing parts that are not authorized or approved by our company.
 - When the product label information is inconsistent or damaged, making it impossible to verify the product serial number.

2.2 Repair Warranty

Our company offers a six-month warranty on the repaired parts of the product. If the same component experiences the same failure within this period, you will be entitled to free repair service.

2.3 Service Network

Company	Address	Telephon	Fax
Taipei Headquarters (Taiwan)	No.16, Tzuchiang St., Tucheng Industrial Park, New Taipei City 23678	+886 2-2269-6789	+886 2-2268-6682
Taichung Sales office (Taiwan)		+886 4-2465-2820	+886 4-2463-9926
Kaohsiung Sales office (Taiwan)		+886 7-333-6968	+886 7-536-8758
Fine automation Co., Ltd. (China)	No. 451, Duhui Road, Zhuanqiao Township, Minhang District, Shanghai City 201109	+86 021-64907260	+86 021-6490-7276
FineTek Pte Ltd. (Singapore Branch)	37 Kaki Bukit Place, Level 4 Singapore 416215	+65 6452-6340	+65 6734-1878
FineTek GmbH (Germany Branch)	Bei den Kämpen 26 21220 Seevetal-Ramelsloh, Germany	+49 (0) 4185 8083 0	+49 (0) 4185 8083 80
FineTek Co., Ltd. (Indonesia Branch)	PERGUDANGAN TUNAS BITUNG JL. Raya Serang KM. 13,8, Blok C3 No. 12&15, Bitung Cikupa, Tangerang 15710	+62 021-2958-1688	+62 021-2923-1988

3. Product Inspection

3.1 Item Verification

- Level sensor 1 set
- Operating Manual 1 copy

3.2 Safety Inspection

- Before unboxing, please check the outer packaging for any deformation or damage and take photos as proof for future compensation claims.
- After unboxing, please check the contents for any deformation, damage, or quality issues, and take photos as proof for future claims.
- After opening the box, please immediately verify that the contents match your order, and that the quantity is correct.
- If there are any irregularities, please contact our company within 7 days of receipt (including photos). Otherwise, we will not provide free replacement or repair.

3.3 Handling & Transportation

- Please avoid dropping, colliding, or applying excessive impact, as this may cause electric shock and damage.
- Do not place the product in the same space as strong magnetic objects.

4. Product Introduction

4.1 Product introduction

The JFR4 FMCW Radar Level Transmitter is a high-frequency, 80GHz intelligent level measurement instrument designed for non-contact measurement of material and liquid levels. The device features an optimized antenna and a new, fast microprocessor that enables high-speed signal analysis and processing, making it ideal for level measurement in storage tanks, silos, and similar applications.

The transmitter provides RS-485 digital signal output and 4-20mA analog signal output, ensuring easy integration with downstream applications.

It is dustproof and waterproof, making it suitable for use in outdoor or industrial environments. It can be used for industrial measurements in tanks and for liquid level measurement in industrial and environmental applications.

4.2 Theory

The radar level transmitter functions by emitting a continuous radar signal known as a Frequency Modulated Continuous Wave (FMCW) through its antenna. A frequency difference arises between the transmitted wave and the echo reflected from the surface of the object, which is directly proportional to the distance between the antenna and the object's surface. Upon receiving the echo, the electronic components process the signal using Fast Fourier Transform (FFT) and advanced high-precision algorithms, allowing the instrument to accurately measure the level.

5. Appearance And Dimension

(Unit: mm)

JFR481

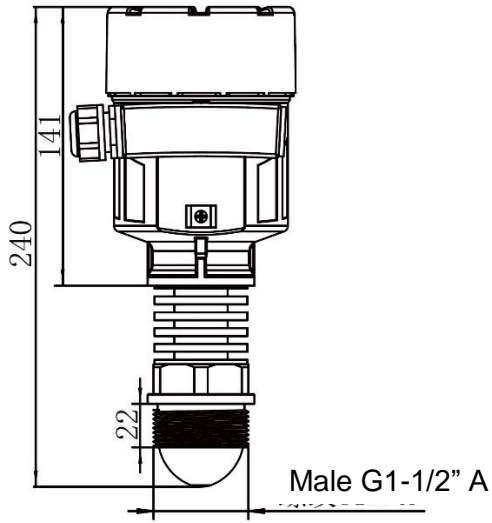

JFR484

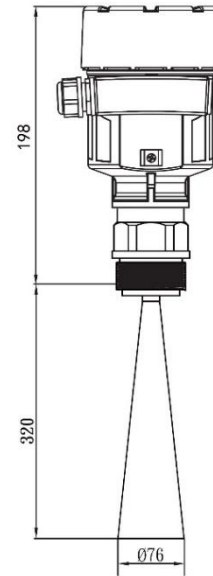

JFR483

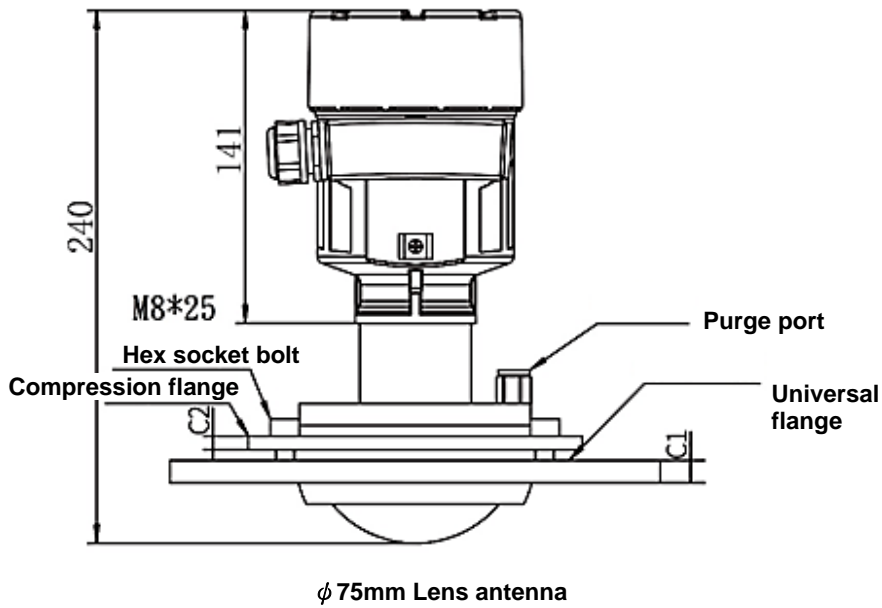

JFR485

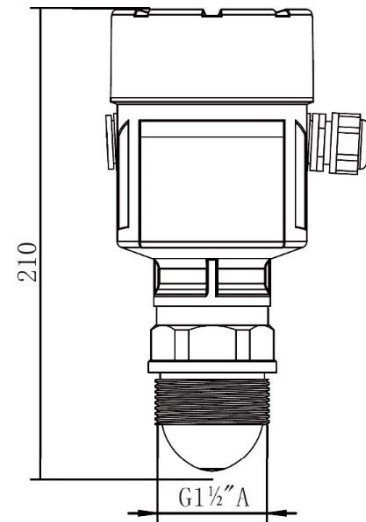

6. Installation Instructions

6.1 Installation Instructions for JFR481 Radar

When installing the radar, please observe the following instructions to ensure proper installation:

1. Ensure sufficient installation space is available.
2. Avoid installing in locations with strong vibrations.
3. The installation position should ideally be at 1/6 or 1/4 of the tank diameter.
4. When installing in tanks with a small diameter, please ensure a minimum installation distance of $\geq 200\text{mm}$.
5. The beam angle of the radar wave depends on the size of the antenna. The optimal measurement conditions occur when the emitted radar wave signal can directly reach the surface of the medium perpendicularly, without being obstructed or reflected by any internal devices within the vessel.

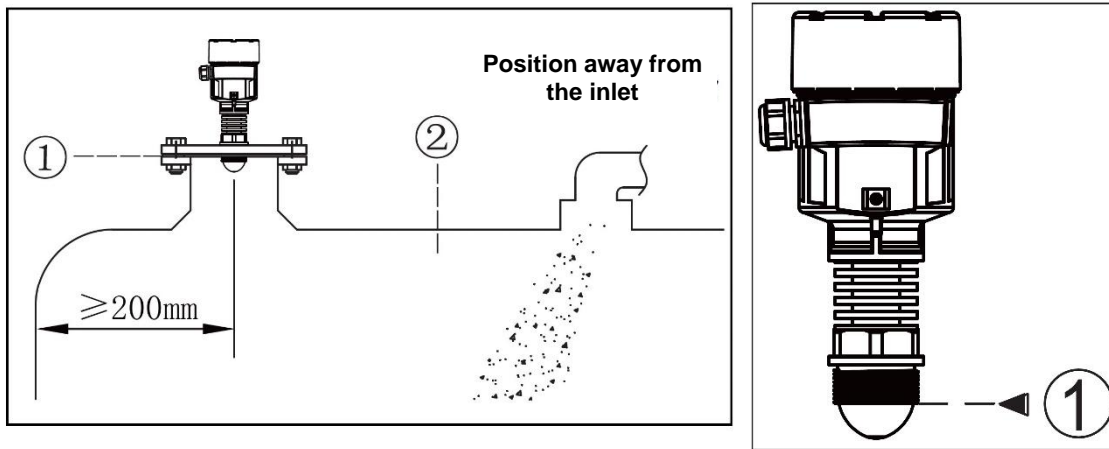

Notes:

① Datum level

② The center or the axis of symmetry of the vessel

6. Conical flat-top tanks: install the radar at the center of the tank top to measure the bottom of the conical vessel.

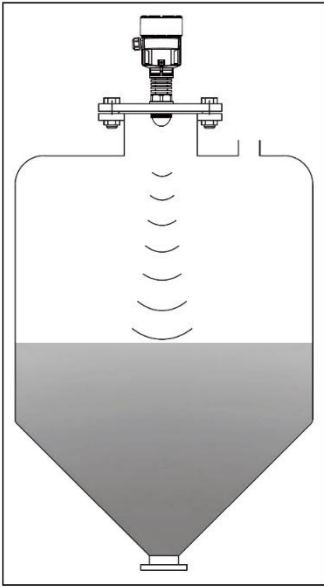

7. Due to the radar wave's narrow beam angle, it is minimally affected by agitators. However, if the agitator has a large diameter and the beam angle cannot fully avoid it, it is recommended to perform a false echo storage procedure while the empty tank's agitator is running.

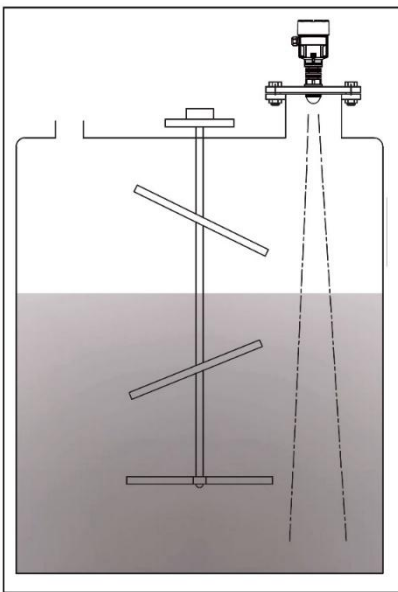

8. Do not install the radar directly above the inlet. Additionally, ensure proper sunshade and rain protection measures are taken for outdoor installations.

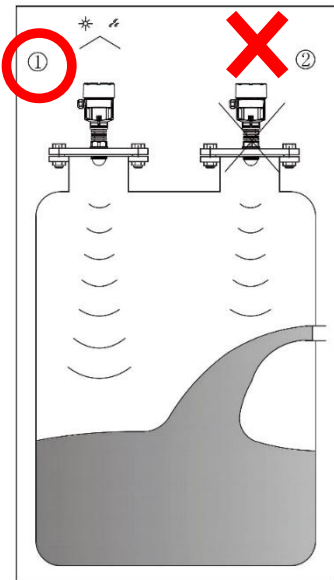

9. The radar should not be installed at the center of a curved vessel, as it can be affected by multiple echoes.

The curved tank top can produce echoes which may have a stronger amplitude than the true echo, hence the center position is unsuitable for installation.

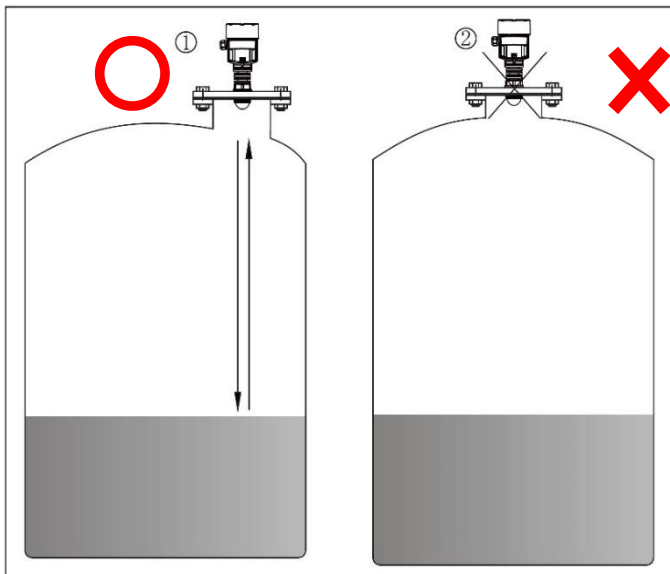

10. Container Connection

It is highly recommended that the extension pipe length for on-site tank installations be ≤ 200 mm. An extension pipe length of ≤ 200 mm is considered very ideal for installation.

If a longer extension pipe is required, please refer to the following size chart. Ideally, the maximum extension length should be less than the dimensions shown in the chart. Additionally, the pipe's end must be smooth with no burrs or protrusions. If necessary, use the "false echo storage" function to eliminate signal reflections from the end of the extension pipe.

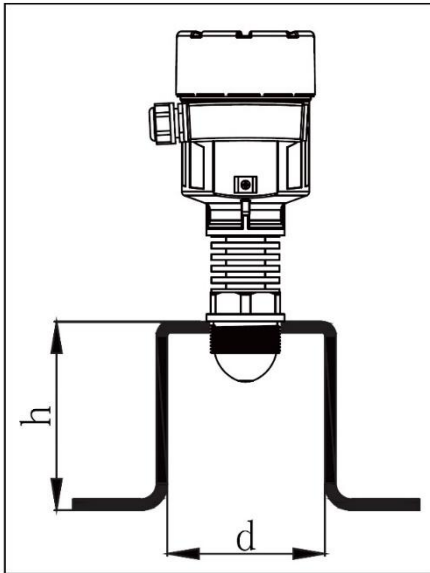

Extension Pipe Diameter (d)	Extension Pipe Length (h)
50mm (2")	≤ 200 mm
80mm (3")	≤ 300 mm
100mm (4")	≤ 400 mm
150mm (6")	≤ 500 mm

Ø45mm Probe

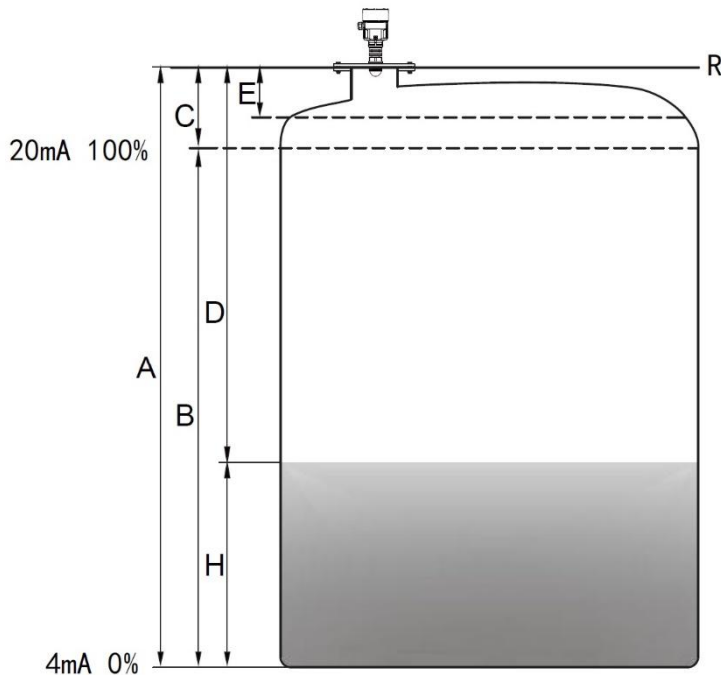

- A. Low Level Adjustment
- B. Measurement Range
- C. High Level Adjustment
- D. Empty Height
- E. Blind Area Range
- H. Material Height
- R. Measurement Reference Point

Notes: When using radar for measurement, ensure that the maximum material level does not enter the measurement blind area (indicated by "E" in the diagram).

6.2 Installation Instructions for JFR483 Radar

When installing the radar, please observe the following instructions to ensure proper installation:

1. Ensure sufficient installation space is available.
2. Avoid installing in locations with strong vibrations.
3. The installation position should ideally be at 1/6 or 1/4 of the tank diameter.
4. When installing in tanks with a small diameter, please ensure a minimum installation distance of $\geq 200\text{mm}$.
5. The beam angle of the radar wave depends on the size of the antenna. The optimal measurement conditions occur when the emitted radar wave signal can directly reach the surface of the medium perpendicularly, without being obstructed or reflected by any internal devices within the vessel.

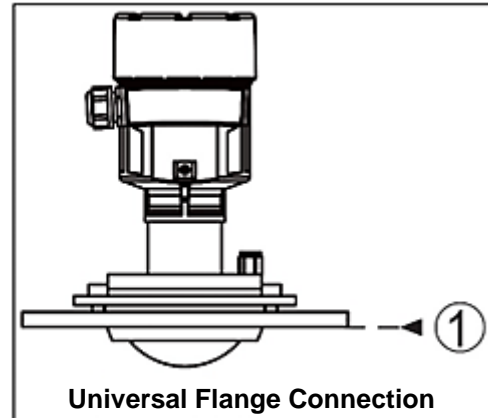
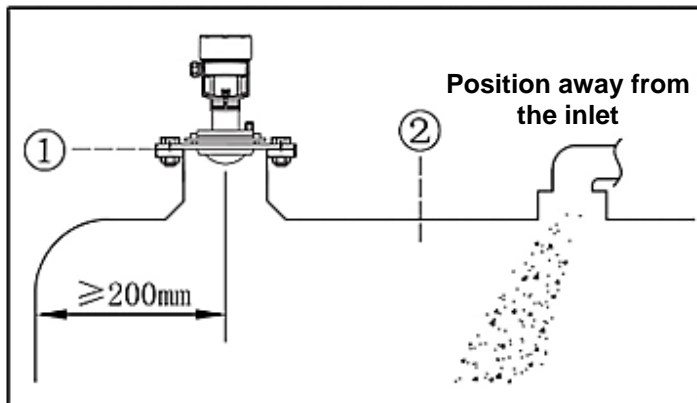

Notes:

- ① Datum level
- ② The center or the axis of symmetry of the vessel

6. Vessels with piled materials

The antenna should be aligned perpendicularly to the slope. If the slope is uneven or the angle at rest is steep, a universal flange must be used to adjust the antenna angle, ensuring it is properly aligned with the slope.

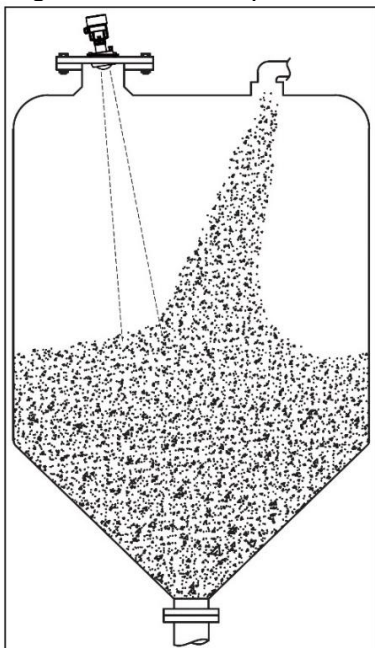

7. Vessel Connection

It is highly recommended that the extension pipe length for on-site tank installations be ≤ 200 mm. An extension pipe length of ≤ 200 mm is considered very ideal for installation.

If a longer extension pipe is required, please refer to the following size chart. Ideally, the maximum extension length should be less than the dimensions shown in the chart. Additionally, the pipe's end must be smoothed with no burrs or protrusions. If necessary, use the "false echo storage" function to eliminate signal reflections from the end of the extension pipe.

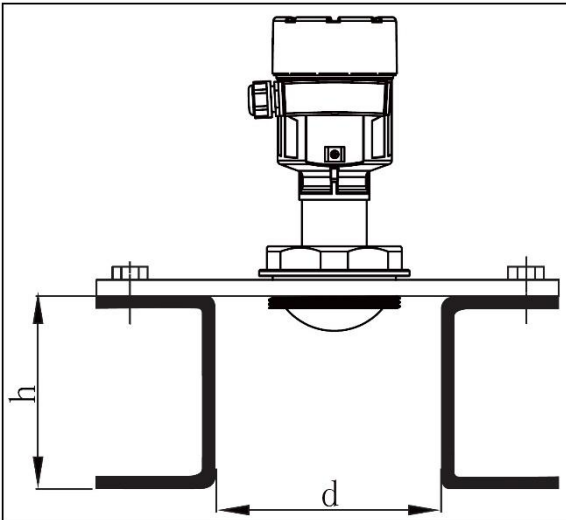

Extension Pipe Diameter (d)	Extension Pipe Length (h)
80mm (3")	≤ 400 mm
100mm (4")	≤ 500 mm
150mm (6")	≤ 600 mm

Ø75mm Lens Antenna

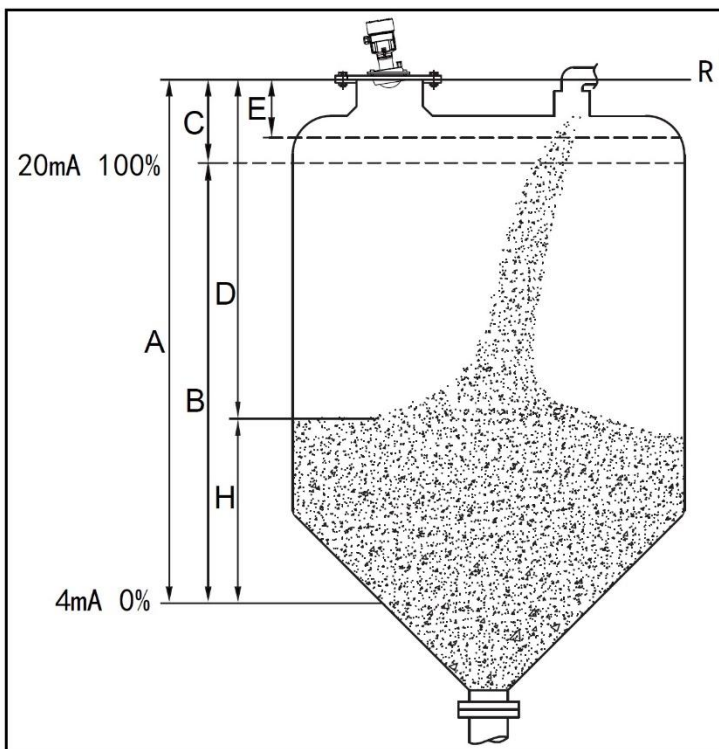

- A. Low Level Adjustment
- B. Measurement Range
- C. High Level Adjustment
- D. Empty Height
- E. Blind Area Range
- H. Material Height
- R. Measurement Reference Point

Notes: When using radar for measurement, ensure that the maximum material level does not enter the measurement blind area (indicated by "E" in the diagram).

6.3 Installation Instructions for JFR484 Radar

When installing the radar, please observe the following instructions to ensure proper installation:

1. Ensure sufficient installation space is available.
2. Avoid installing in locations with strong vibrations.
3. The installation position should ideally be at 1/6 or 1/4 of the tank diameter, depending on the specific tank size, and the minimum distance from the tank wall should be $\geq 300\text{mm}$.
4. The radar signal is focused into a conical beam through the antenna system, and the beam angle depends on the size of the antenna. Any object within the conical beam angle will reflect the radar signal, with particularly strong false reflections occurring near pipes, supports, or other structures. For distant false reflection surfaces, the radar signal's energy is dispersed over a larger area, resulting in weaker reflected signals that have less impact on the measurement compared to closer false echoes. The optimal measurement conditions occur when the emitted radar wave signal can directly reach the surface of the medium perpendicularly, without being obstructed or reflected by any internal devices within the vessel.
5. Position away from the inlet

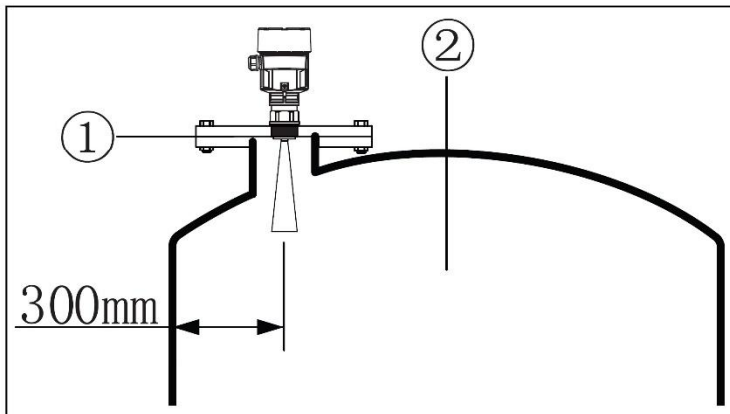

Notes:

- ① Datum level
- ② The center or the axis of symmetry of the vessel

6. Vessels with piled materials

The antenna should be aligned perpendicularly to the slope. If the slope is uneven or the angle of repose is steep, a universal flange must be used to adjust the antenna angle, ensuring it is properly aligned with the slope.

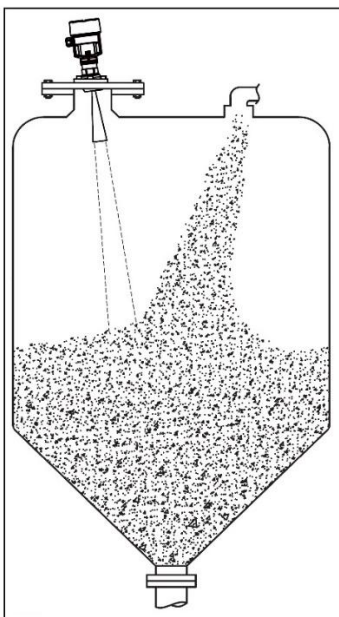

7. Vessel Connection

For the extension pipe installation, it is recommended that the antenna extends up to 10mm from the inner wall of the vessel.

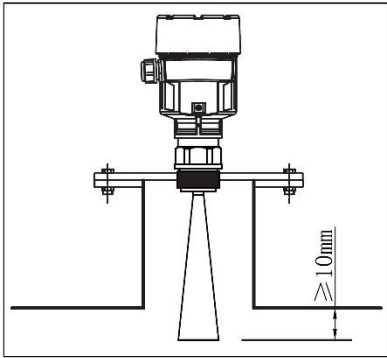

When installed inside the extension pipe, the relationship between the maximum length (h) and the pipe diameter (d) is as follows:

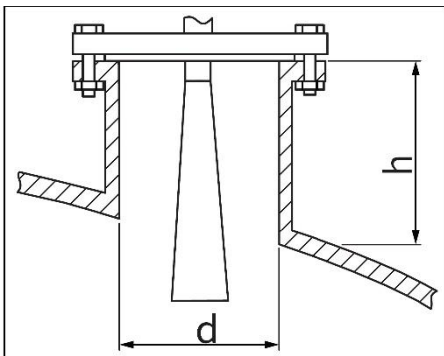

Extension Pipe Diameter (d)	Extension Pipe Length (h)
80mm (3")	≤1000 mm
100mm (4")	≤1500 mm
150mm (6")	≤2000 mm

Measurement performance is significantly compromised when the maximum extension pipe length is exceeded. Please observe the following guidelines:

- The bottom of the extension pipe must be smooth and free of burrs.
- The edges of the extension pipe should be rounded.
- Interference echo suppression must be implemented.

Note: As a general guideline, it is recommended that the extension pipe length be less than 300mm.

If a longer pipe is installed on-site, ensure that the maximum length does not exceed the values specified in the table, which shows the allowable extension pipe lengths corresponding to different pipe diameters.

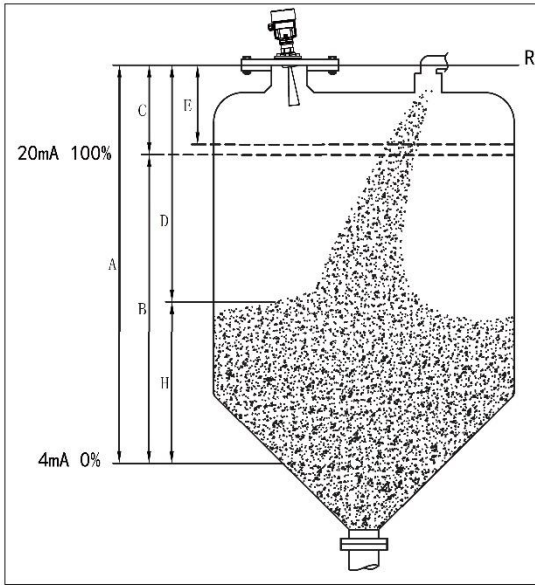

- A. Low Level Adjustment
- B. Measurement Range
- C. High Level Adjustment
- D. Empty Height
- E. Blind Area Range
- H. Material Height
- R. Measurement Reference Point

Notes: When using radar for measurement, ensure that the maximum material level does not enter the measurement blind area (indicated by "E" in the diagram).

6.4 Installation Instructions for JFR485 Radar

When installing the radar, please observe the following instructions to ensure proper installation:

1. Ensure sufficient installation space is available.
2. Avoid installing in locations with strong vibrations.
3. The installation position should ideally be at 1/6 or 1/4 of the tank diameter.
4. For tanks with a small diameter, ensure a minimum installation distance of $\geq 200\text{mm}$.
5. The beam angle of the radar wave depends on the size of the antenna. The optimal measurement conditions occur when the emitted radar wave signal can directly reach the surface of the medium perpendicularly, without being obstructed or reflected by any internal devices within the vessel.

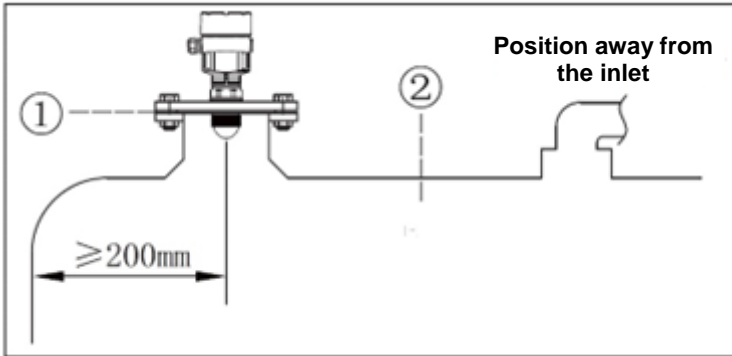

Notes:

- ① Datum level
- ② The center or the axis of symmetry of the vessel

6. Bracket Installation

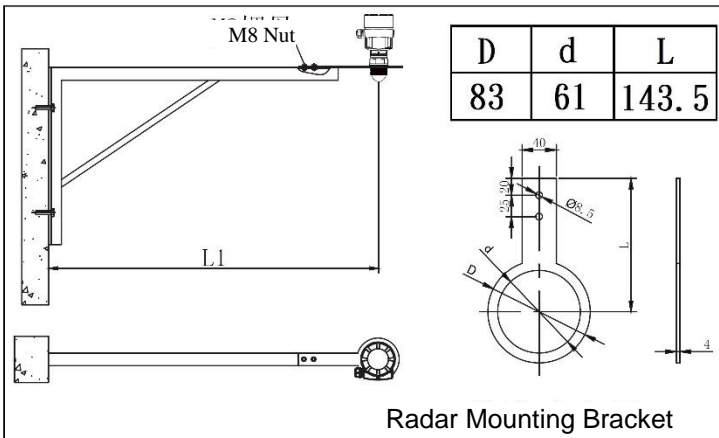

7. Do not install the radar directly above the inlet. Additionally, ensure proper sunshade and rain protection measures are taken for outdoor installations.

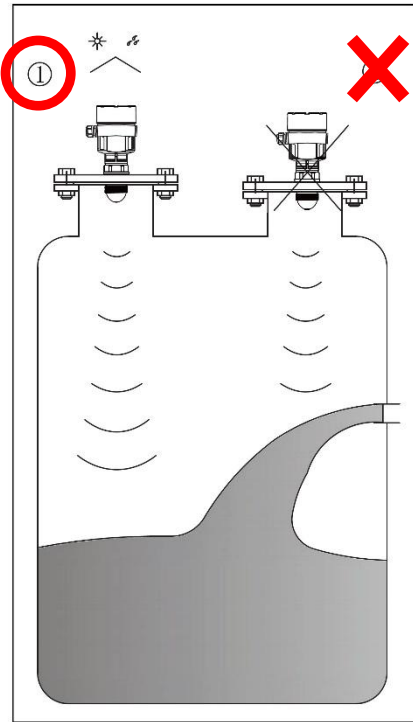

8. The radar should not be installed at the center of a curved vessel, as it can be affected by multiple echoes. The curved tank top can produce echoes which may have a stronger amplitude than the true echo, hence the center position is unsuitable for installation.

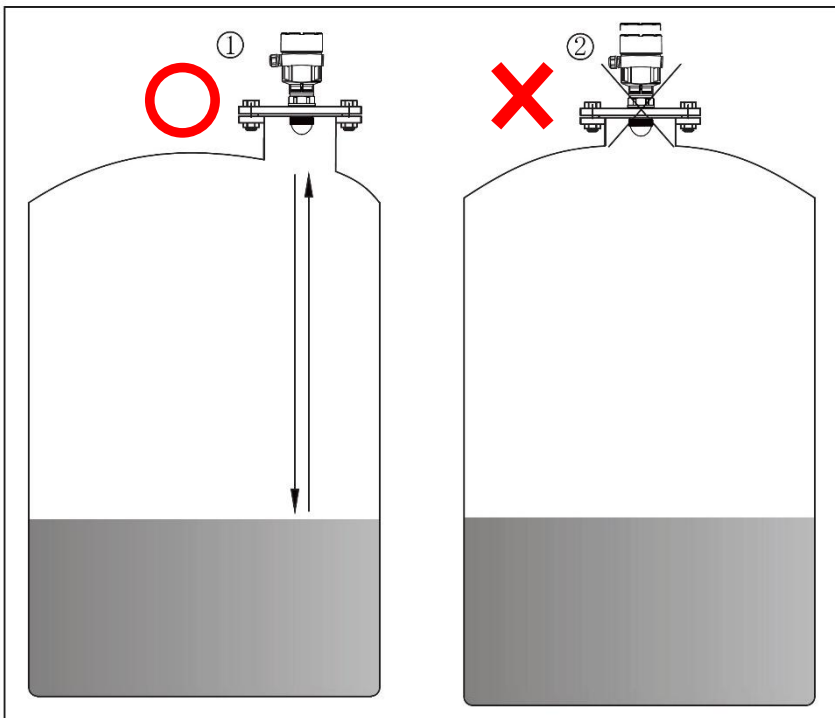

9. Vessel Connection

It is highly recommended that the extension pipe length for on-site tank installations be ≤ 200 mm. An extension pipe length of ≤ 200 mm is considered very ideal for installation.

If a longer extension pipe is required, please refer to the following size chart. Ideally, the maximum extension length should be less than the dimensions shown in the chart. Additionally, the pipe's end must be smoothed with no burrs or protrusions. If necessary, use the "false echo storage" function to eliminate signal reflections from the end of the extension pipe.

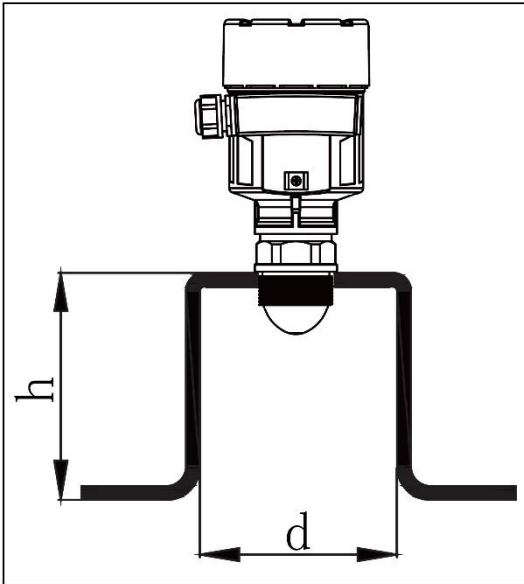

Extension Pipe Diameter (d)	Extension Pipe Length (h)
50mm (2")	≤ 200 mm
80mm (3")	≤ 300 mm
100mm (4")	≤ 400 mm
150mm (6")	≤ 500 mm

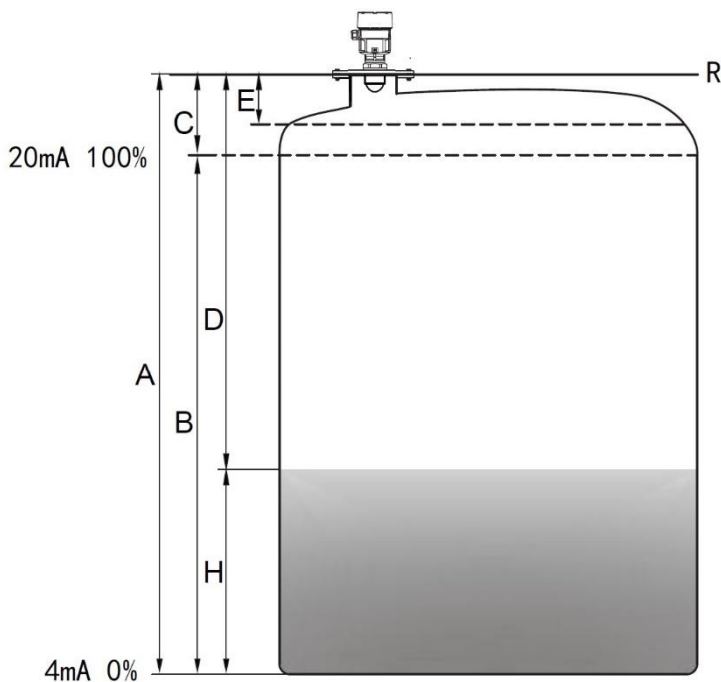

- A. Low Level Adjustment
- B. Measurement Range
- C. High Level Adjustment
- D. Empty Height
- E. Blind Area Range
- H. Material Height
- R. Measurement Reference Point

Notes: When using radar for measurement, ensure that the maximum material level does not enter the measurement blind area (indicated by "E" in the diagram).

7. Electrical Connection

7.1 Installation Instructions for JFR484 Radar

4~20mA (Two-wire): 24VDC power supply

The power supply and output current signal share a single two-core shielded cable.

4~20mA (Four-wire): 24VDC power supply

The power supply and current signal are separate, and shall use either two two-core shielded cables or one four-core shielded cable.

7.2 Cable Installation

Cable outer diameter: 6~9mm(M20x1.5)

Cable outer diameter: 3.5mm~8.7mm(1/2NPT)

4~20mA (Two-wire): A two-core shielded cable can be used for the power supply.

4~20mA (Four-wire): A four-core shielded cable can be used for the power supply.

7.3 Cable Shielding and Grounding

Ideally, the shielding should be grounded at both ends. Please note that a compensating current may pass through the ground.

When grounding at both ends, a capacitor with grounded potential (e.g., 1 μ F, 1500V) can be connected at one end (e.g., the distribution panel).

Use the lowest possible resistance for grounding.

(Note: If the radar is used in an explosive environment, grounding at both ends must be strictly avoided due to potential output.)

7.4 Cable Shielding and Grounding

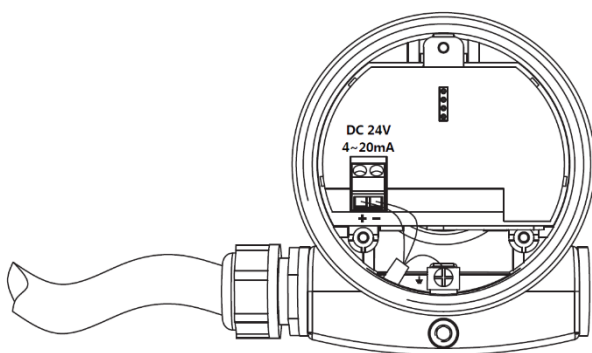

Two-wire Wiring Diagram:
24VDC power supply, 4~20mA output.

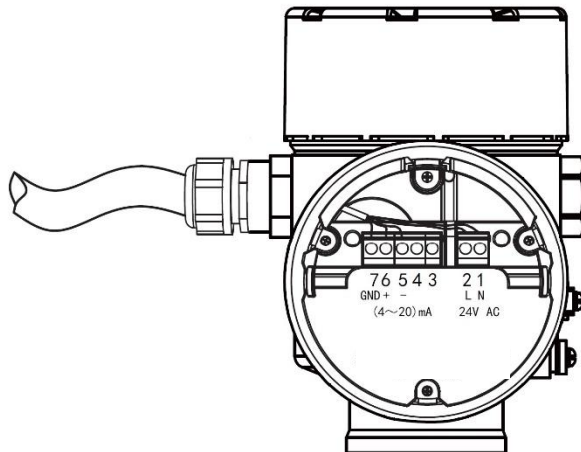

Four-wire Wiring Diagram:
24VDC power supply, 4~20mA output.

Note: When not output(4-20mA), the 5 and 6 power supplies need to be wired in reverse

7.5 Safety Instructions

All electrical connections must be performed with the power off. Please follow the guidelines provided in the manual!

Adhere to local electrical installation procedures.

Comply with local health and safety procedures. All operations on the radar's electrical components must be conducted by properly trained professionals.

Please refer to the radar's nameplate to ensure that the product specifications meet requirements.

Ensure power supply voltage matches the specifications on the radar's nameplate.

7.6 Protection Rating

The radar fully meets IP67 protection rating requirements. Ensure waterproof integrity of the cable glands. As shown in the diagram:

How to ensure the installation meets IP67 requirements:

- Make sure the cable glands are intact.
- Ensure the cables are in good condition without damage.
- Ensure that the cables used meet the electrical connection specifications. Before connecting to the electrical interface, bend the cable downward to prevent water from entering the enclosure (see Figure①).
- Tighten the cable gland securely (see Figure②).
- Seal any unused electrical interfaces with blanking plugs (see Figure③).

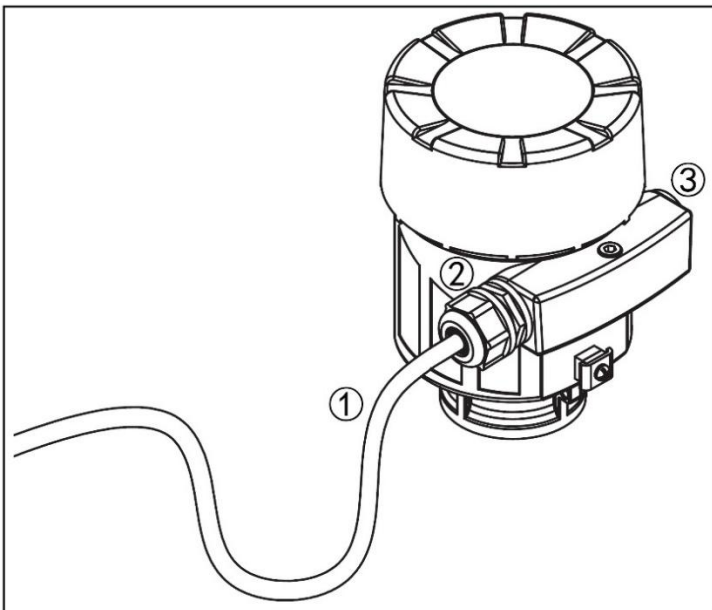



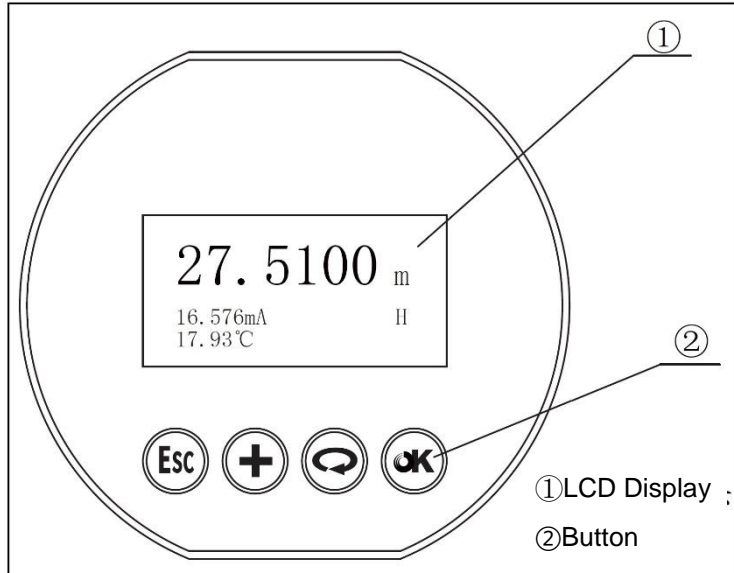

8. Operating Instructions

8.1 Installation Instructions for JFR484 Radar

The transmitter settings can be configured using the 4 buttons on the panel. The language for the configuration menu is selectable. After configuration, it is primarily used for display purposes, allowing measurement values to be read clearly through the window.







8.2 Button Functions

	<ul style="list-style-type: none"> -Exit the edit menu state or return to the previous level of the function menu -Toggle between display values and echo curve interface (on the home page)
	<ul style="list-style-type: none"> -Toggle between the function menu items -Modify the parameter values, cycling through 0–9 indefinitely -Toggle between the curve display mode or home page display mode
	<ul style="list-style-type: none"> -Toggle between the function menu items -Change the cursor position
	<ul style="list-style-type: none"> -Enter the edit menu mode -Confirm the menu -Confirm parameter modifications

8.3 Button Functions

(1) Enter the Main Menu

In operation mode, pressing the  button will display the main menu. A triangular cursor appears on the left side of the main menu; pressing the  button will move the cursor to a different position. Pressing the  button will enter the menu item indicated by the cursor, while pressing the  button will exit the current option. The display interface is as follows:

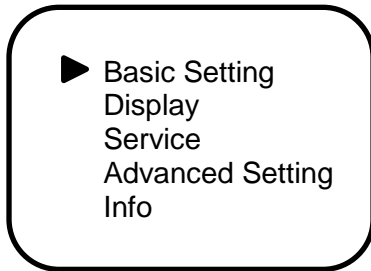

(2) Set Measurement Range

The display interface is as follows:

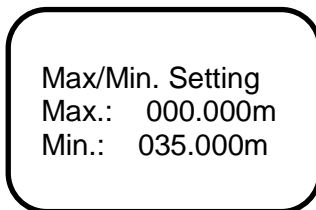

Press the  button to enter basic settings and select the high and low level settings. For example:

① Under normal circumstances, if the distance from the measurement reference point to the bottom of the tank is 35m, the "Low Level" should be set to 35.000m, and the "High Level" should be set to 00.000m.

② Under special circumstances, if production requires the highest level to be displayed at a specific height (for instance, when a 10m high tank needs to be filled to 2m below the top to prevent hazards), the "Low Level" should be set to 10.000m, and the "High Level" should be set to 02.000m.

The display interface is as follows:



(3) Measurement Range



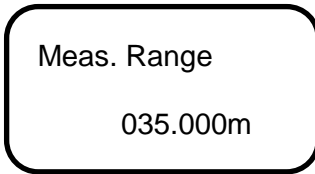

The display interface is as follows:



Note: This range is not the output range of the radar but rather the maximum range for processing the reflected echoes (Setting value: Range setting \geq Low level adjustment). For example, if you want to start measuring from the bottom of the tank and the output range is set to 10m, you would set the "Measurement Range" to 9m, the "Low Level" to 10m, and the "High Level Adjustment" to 0m. The output range of the radar does not change. Instead, the measurement will exclude the 1m level just below the bottom of the tank. Additionally, when the tank is empty, the radar may not detect the bottom of the tank, leading to potential fluctuations in the readings.

(4) Blind Area Settings

When there are fixed obstacles near the surface of the distance sensor that interfere with measurements, and the maximum material height will not reach the obstacle, the blind area range setting feature can be used to avoid measurement errors. Press the  button to enter the blind area range setting menu.

Press the  button to highlight the corresponding parameter field, then use the [Select] or  button and  button to set the parameters. Press the  button to confirm.

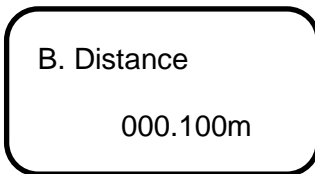

(5) Setting Display Content

After entering the "Display" menu, the first submenu is "Display Content." After setting the options, the radar will display the corresponding content. The factory default value is generally set to the material level.

The display interface is as follows:

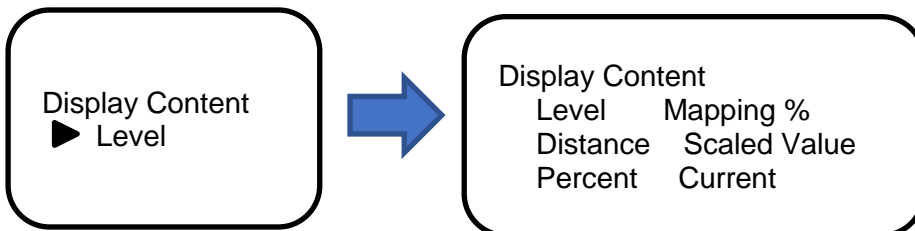

Display Content Explanation:

① Empty Height: The distance from the measurement reference point to the surface of the medium.

② Level: The height of the level, which is equal to "low level" minus "empty height."

(6) False Echo

The false echo function can eliminate the influence of interference waves on the true signal under certain circumstances.

Enter the "Service" menu; the first submenu is "False Echo." Click the  button to access the settings interface.

The display interface is as follows:

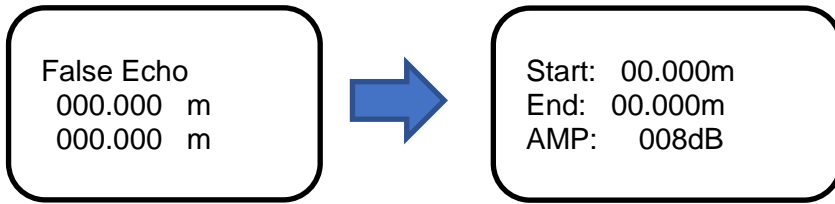

(7) Select Current Output

Enter the "Service" menu; the second submenu is "Current Output." Click the button to access the setting interface.

The display interface is as follows:

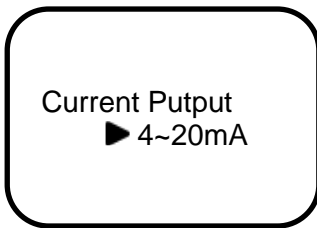

Current Output: The direction of the current output when the radar is operating can be selected. The default setting is 4-20mA, where the output current is linearly proportional to the material level. If 20-4mA is selected, the output current will be inversely proportional to the material level.

9. Menu Overview

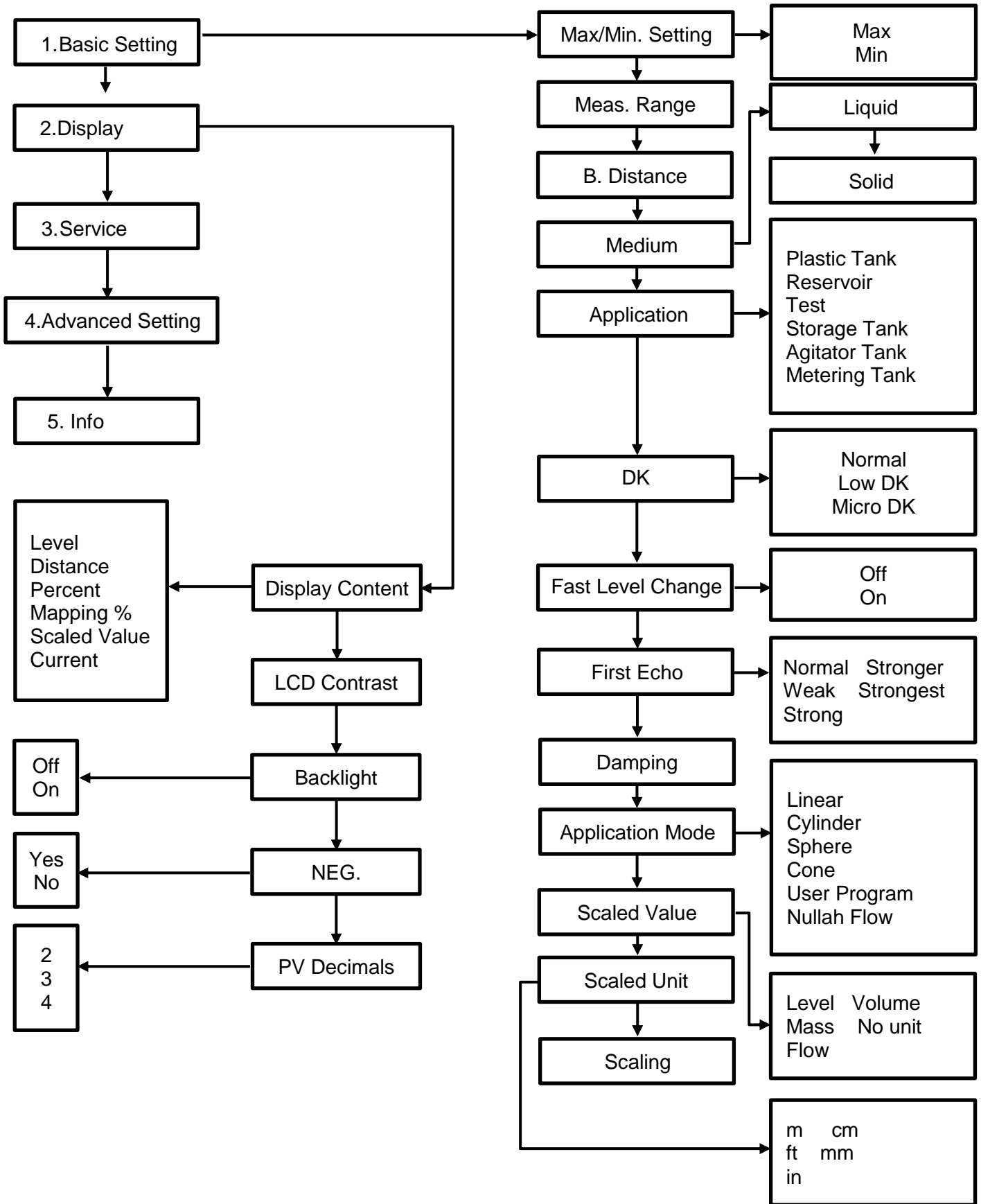

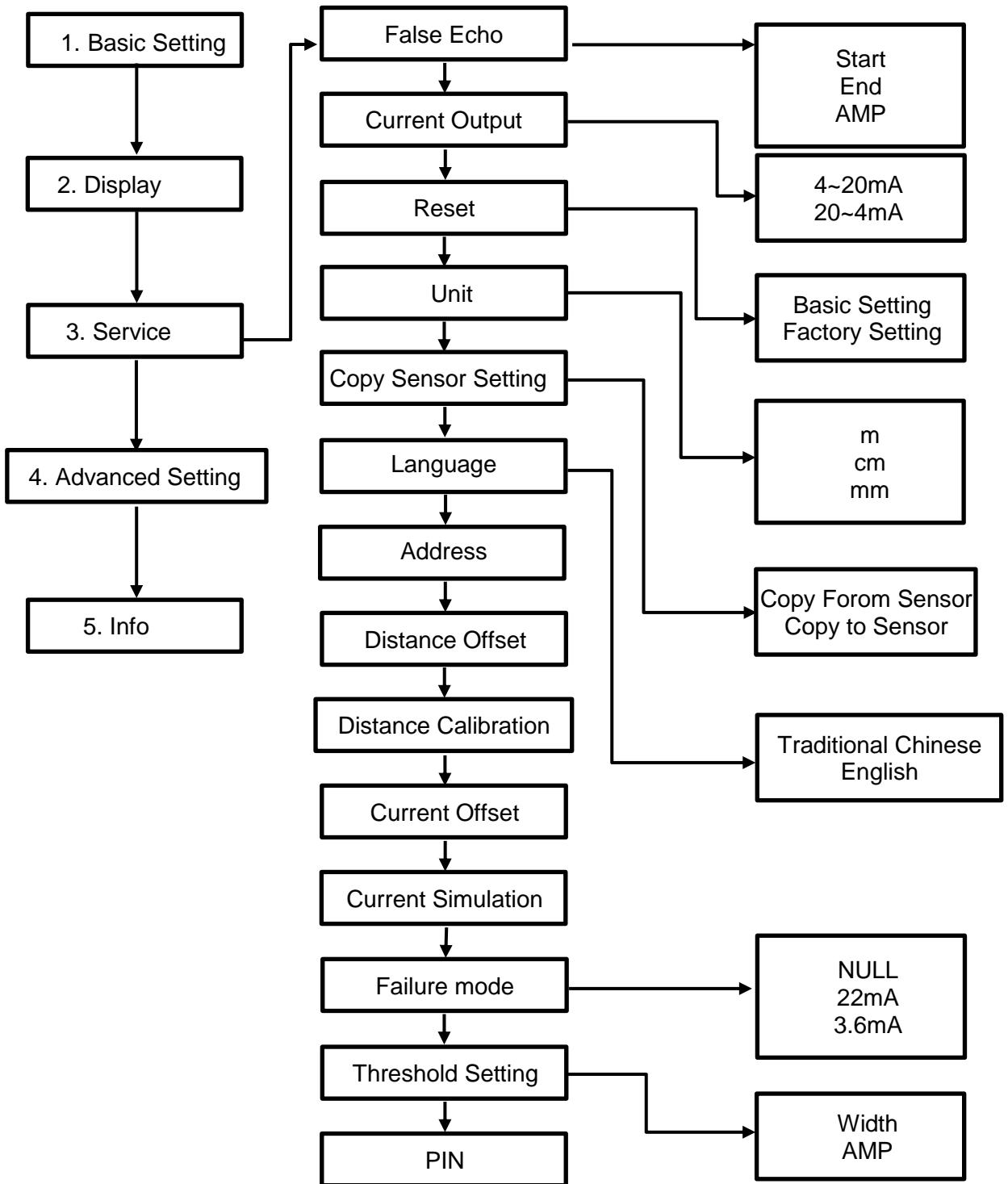

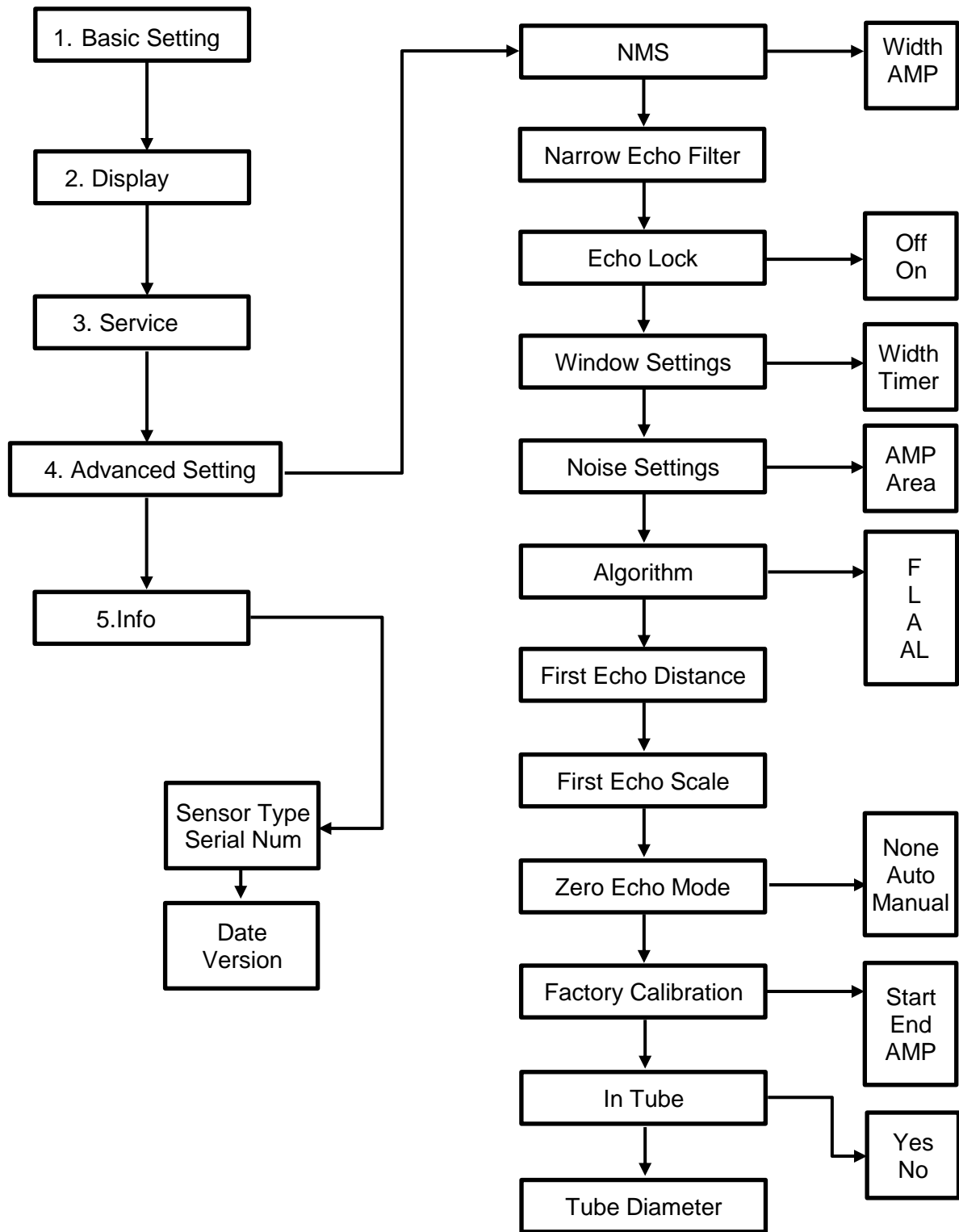

10. Transportation and Storage

In addition to complying with the requirements , the transportation and storage conditions for the level transmitter must also meet the following requirements:

1. During transportation, the level transmitter should be handled strictly according to the product's characteristics and the instructions provided in the manual.
2. Execute the necessary precautions to prevent rain and moisture.
3. Reduce vibration and prevent collisions during transport.
4. The level transmitter should be stored in a dry and well-ventilated indoor environment with a temperature range of -20 to 60°C and a relative humidity not exceeding 80%.
5. Do not store with corrosive substances.
6. Ultrasonic devices that have been stored for an extended period must undergo appropriate testing before

11. MODBUS Communication Protocol

Default connection configuration: Address ID: 1, Baud rate: 9600, Data format: 8N1

Address(Hex)	Address(Dec)	Definition (not consecutive reading)	Authority
0x0000	0	Headspace value (unit: cm)	Read only
0x0001	1	Headspace value (unit: mm)	Read only
0x0002	2	Water level value (unit: cm)	Read only
0x0003	3	Water level value (unit: mm)	Read only
0x0010	16	Read measurement status; =0 normal, >0 error	Read only
0x0011	17	Measuring range (unit: cm)	Read/write
0x0012	18	Blind zone (unit: cm)	Read/write
0x0013	19	Low level adjustment (unit: cm)	Read/write
0x0014	20	High level adjustment (unit: cm)	Read/write