



# EPU Clamp-On Ultrasonic Flow Meter Operation Manual



## **FineTek Co., Ltd.**

No.16, Tzuchiang St., Tucheng Industrial Park, New Taipei City 23678

Tel: 886-2-22696789

Fax: 886-2-22686682

Website: <http://www.fine-tek.com>

E-mail: [info@fine-tek.com](mailto:info@fine-tek.com)

08-EPU-B10-EK,03/03/2026

# CONTENTS

<b>1. Reading labels .....</b>	<b>1</b>
<b>2. Product warranty .....</b>	<b>2</b>
2.1 New product warranty .....	2
2.2 Repair warranty .....	2
2.3 Service network .....	3
<b>3. Storage And Transport Requirements .....</b>	<b>4</b>
3.1 Transport Requirements.....	4
<b>4. Product Inspection .....</b>	<b>5</b>
4.1 Package Contents .....	5
4.2 Safety Inspection .....	5
4.3 Handling of the product .....	5
<b>5. Product Overview .....</b>	<b>6</b>
5.1 Product Features .....	6
5.2 Working Principles.....	6
5.3 Sound Velocity In Liquid.....	7
5.4 Sound Velocity In Pipe Material .....	7
5.5 Pipe Diameter Flow Rang .....	7
5.6 Terms And Definitions .....	8
<b>6. Product Specifications .....</b>	<b>9</b>
6.1 Product Specifications.....	9
6.2 Transmitter Dimension .....	10
<b>7. Parameter Description .....</b>	<b>12</b>
7.1 Display Interface .....	12
7.2 Button Function.....	12
7.3 Menu Setting Process.....	13
<b>8. Wiring Instructions .....</b>	<b>14</b>
8.1 Electrical Specifications.....	14
8.2 Electrical Specifications.....	15
<b>9. Installation Instructions .....</b>	<b>16</b>
9.1 Environmental Safety .....	16
9.2 Installation Of Circuits .....	16
9.3 Precautions .....	16
9.4 Electrification Instructions.....	17
<b>10. Installation Steps of Transducers .....</b>	<b>18</b>
10.1 Selection of the Installation Location .....	18
<b>11. Parameter Settings and Functions .....</b>	<b>30</b>
11.1 Menu Setting Process.....	30
<b>13. Error Message and Troubleshooting.....</b>	<b>32</b>
<b>12. MODBUS Communication Protocol.....</b>	<b>33</b>

## 1. Reading labels

Thanks for purchasing FineTek's Product. This operation manual describes the product features, working principles, operation and maintenance methods. It makes the user fully understand how to use the product correctly, so as to prevent dangerous situations such as device damage or operator injury.

- Please read this operation manual completely and carefully before using the product.
- Please contact the company if this operation manual can't satisfy your demands.
- The content of the operation manual is updated based on the version upgrade, which will be uploaded to the website for the user to access.
- Please don't disassemble or repair the product on your own, as this will make you disqualified from availing of the warranty service. Please send the product back to the company for repair and calibration, or just contact the company.
- Explanation of warning signs:



Danger→ It indicates that wrong operation will cause death or major disasters.



Note→ It indicates that wrong operation will cause injury and device damage to some extent.



Electric shock→ It warns of possible electric shock.



Fire→ It warns of possible fire.



Prohibited→ It indicates the prohibited wrong behavior.

## 2. Product warranty

### 2.1 New product warranty

- We don't charge for the inspection, part/s and repair for the product of the company that has a defect within 12 months from the delivery date and meets the warranty terms.
- If the product defect is not due to human error during its transportation, user may change to a new unit from the company within 7 days from delivery date.
- When the product needs to be sent back to the factory for repair, please send the whole set, and don't disassemble the parts. Moreover, please be sure it is completely packed to avoid damage and causing more loss and defect during the transportation.
- The warranty is not available for causes that fall under the following circumstances, for which the company shall charge for the inspection, part/s and repair according to the actual condition:
  - The product or its parts are beyond the warranty period.
  - Fault or damage is caused by not following the instruction and use environment described on the operation manual.
  - The product damage is caused by a force majeure factor (natural disasters, floods, fire, earthquakes, lightning, typhoon, etc.), human destruction (scratches, dropping, latch broken, tapping, cracks and punching), human error (using improper voltage, high-humidity, water leakage, stain, corrosion, loss, improper storage, etc.) and other abnormal factors.
  - The damage is caused by the customer or the 3rd party through the installation, addition, expansion, modification and repair of parts not authorized or certified by the company.
  - The volume label information is wrong or unclear, so the product serial number can't be confirmed.

### 2.2 Repair warranty

A **6-month** warranty service is provided for the repaired part of the product, during which the same product can be repaired free of charge in case of the same fault.

### 2.3 Service network

Company	Address	Telephon	Fax
<b>Taipei Headquarters (Taiwan)</b>	No.16, Tzuchiang St., Tucheng Industrial Park, New Taipei City 23678	+886 2-2269-6789	+886 2-2268-6682
<b>Taichung Sales office (Taiwan)</b>		+886 4-2465-2820	+886 4-2463-9926
<b>Kaohsiung Sales office (Taiwan)</b>		+886 7-333-6968	+886 7-536-8758
<b>Fine automation Co., Ltd. (China)</b>	No. 451, Duhui Road, Zhuanqiao Township, Minhang District, Shanghai City 201109	+86 021-64907260	+86 021-6490-7276
<b>Aplus FineTek Sensor Inc. (America)</b>	355 S. Lemon Ave, Suite D, Walnut, CA 91789	1 909 598 2488	1 909 598 3188
<b>FineTek Pte Ltd. (Singapore Branch)</b>	37 Kaki Bukit Place, Level 4 Singapore 416215	+65 6452-6340	+65 6734-1878
<b>FineTek GmbH (Germany Branch)</b>	Bei den Kämpen 26 21220 Seevetal-Ramelsloh, Germany	+49 (0) 4185 8083 0	+49 (0) 4185 8083 80
<b>FineTek Co., Ltd. (Indonesia Branch)</b>	PERGUDANGAN TUNAS BITUNG JL. Raya Serang KM. 13,8, Blok C3 No. 12&15, Bitung Cikupa, Tangerang 15710	+62 021-2958-1688	+62 021-2923-1988

## 3. Storage And Transport Requirements

### 3.1 Transport Requirements

To protect the product from damage during the transport, keep it in the package when it is transported from the factory. The place of storage shall meet the following requirements:

- Appropriate rainproof and damp-proof treatment must be conducted.
- Vibration must be reduced and collision with other objects must be prevented during its transportation.
- The storage temperature must be in the range of -20~60°C
- The humidity should be lower than 80%
- Outdoor storage may degrade the performance of the flow meter.

## 4. Product Inspection

### 4.1 Package Contents

The spare parts for S200(DN32~DN150)transducer as below:

- Ultrasonic flow meter transmitter x 1
- Ultrasonic transducer (w/cable) x 2
- Metal transducer bracket x 1
- Stainless steel clamp x 2
- Ultrasonic coupling agent x 1
- Operation manual x 1
- Product inspection report x 1

The spare parts for S800(DN150~DN800)transducer as below:

- Ultrasonic flow meter transmitter x 1
- Ultrasonic transducer (w/cable) x 2
- Stainless steel clamp x 2
- Ultrasonic coupling agent x 1
- Operation manual x 1
- Product inspection report x 1

**Remarks: The metal bracket without transducer enclosed.**

### 4.2 Safety Inspection

- Make sure the package is not deformed or damaged before you unpack the box. If there is any deformation or damage, take a picture and use it as proof for compensation.
- Make sure the contents are not deformed or damaged and there are no quality problems after you unpack the box. If there is any deformation, damage or quality problem, take a picture and use it as proof for compensation.
- Unpack the box and make sure the contents conform to what you ordered and the quantity is correct without delay.
- If there is any nonconformance, contact us within 7 days after the product arrived (with the picture). Otherwise, we are not responsible for the compensation, make-up, replacement or repair.

### 4.3 Handling of the product

- Don't drop or impact the product or impose excessive force on it. Otherwise, electric shock or damage may occur.
- Don't pull the cable of the probe. Otherwise, the cable may become loose or come off.

## 5. Product Overview

### 5.1 Product Features

- When measuring the flow of a pipe, it is not needed to invade the original pipe and, thus, the pipe and the process fluid will not be affected.
- The LCM displays the instantaneous flow, total flow, and empty pipe warning.
- Standard 4-20mA, pulse output, RS485 Modbus communication.
- Rugged design with high reliability for industrial applications.
- Applicable to all kinds of liquids that do not contain air or impurities.

### 5.2 Working Principles

The measuring principle of the transit-time clamp-on ultrasonic flow meter is the ultrasonic pulse striking on the fluid through a transducer. When the ultrasonic wave propagates in the liquid, the flow of the liquid brings about tiny changes to the propagation time, which is in a direct proportion to the flow rate of the liquid, and the flow rate of the liquid can be acquired. As shown in the figure, a pair of ultrasonic transducers are installed onto the outer surface of the pipe whose flow is to be measured according to the relative position. There are "Z" and "V" options available for the installation. The ultrasonic pulse aroused by the electrical impulse from a transducer is propagated through the pipe wall -> fluid -> pipe wall and received by the second transducer. The propagation time of the ultrasonic pulse from the transmission to the receiving ends depending on the forward and reserve flow directions is:

$$T_{UP} = \frac{M \times D / \cos\theta}{C_0 + V \sin\theta}$$

$$T_{DOWN} = \frac{M \times D / \cos\theta}{C_0 - V \sin\theta}$$

$$\Delta T = T_{DOWN} - T_{UP}$$

The average linear flow rate of the fluid is acquired using the formula below:

$$V = \frac{M \times D}{\sin 2\theta} \times \frac{\Delta T}{T_{UP} \times T_{DOWN}}$$

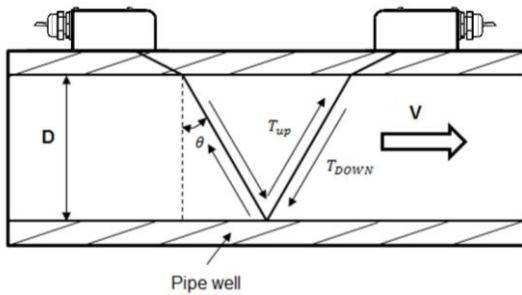

### 5.3 Sound Velocity In Liquid

Liquid	Sound velocity (m/s)
Water (25°C)	1497
Water (50°C)	1543
Water (75°C)	1554
Water (100°C)	1543
Sea water	1510
Methyl alcohol	1121
Ethanol	1168

Liquid	Sound velocity (m/s)
Acetone	1190
Benzene	1330
Toluene	1170
Ethylbenzene	1340
Chlorobenzene	1289

### 5.4 Sound Velocity In Pipe Material

Pipe material	Sound velocity (m/s)
Carbon steel	3200
Stainless Steel	3120
PVC	2280
Copper	2270
Cast iron	2500
FRP	2560
Polycarbonate(Pc)	2300

### 5.5 Pipe Diameter Flow Rang

Diameter (mm)	Flow Rang(M³/h)				
	Flow rate 0.6m/s	Flow rate 1m/s	Flow rate 3m/s	Flow rate 6m/s	Flow rate 15m/s
32	1.73	2.89	8.68	17.37	43.42
40	2.71	4.52	13.57	27.14	67.85
50	4.24	7.06	21.2	42.41	106.02
65	7.16	11.94	35.83	71.67	179.18
80	10.85	18.09	54.28	108.57	271.43
100	16.96	28.27	84.82	169.64	424.1
125	26.5	44.17	132.53	265.06	662.67
150	38.16	63.61	190.84	381.7	954.25
200	67.85	113.09	339.28	678.57	1696.45
250	106.01	176.7	530.13	1060.27	2650.7
300	152.66	254.45	763.39	1526.8	3817.02
350	207.79	346.34	1039.06	2078.14	5195.39
400	271.41	452.36	1357.13	2714.29	6785.81
450	343.5	572.52	1717.62	3435.3	8588.29
500	424.07	706.82	2120.53	4241.11	10602.83
600	610.67	1017.82	3053.57	6107.2	15268.08
700	831.19	1385.37	4156.25	8312.58	20781.56
800	1085.64	1809.46	5428.58	10857.25	27143.27

## 5.6 Terms And Definitions

### Volume flow rate:

means the volume of the liquid flowing through a specific surface within a unit time. It is usually expressed in Q.

The unit under the International System of Units is  $m^3/s$ .

### Cumulative flow:

means the "value of the total flow" from the start to the end of the measurement.

### Sound velocity in liquid:

means the sound transmitting velocity in liquid. Unit: m/s.

### Pipe outer diameter:

means the diameter of a pipe around the outer edge. This is usually acquired from the measurement of the circumference.  $OD = (\text{Pipe circumference}) / (3.1415926)$

### Pipe thickness:

means the thickness of the pipe wall. This is acquired using a thickness gauge or from the standard pipe specification table.

### Sound velocity in pipe material:

means the sound transmitting velocity in pipe material. Unit: m/s.

### Installation distance of transducers:

means the distance from the front edge of a transducer to the front edge of another transducer.

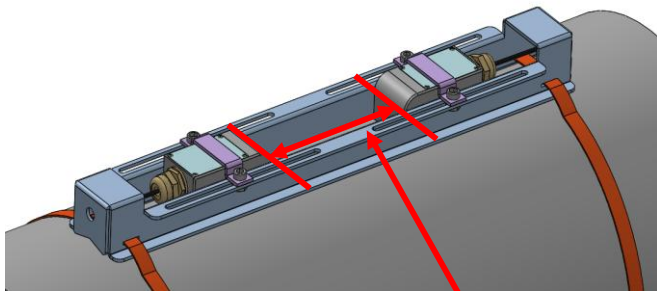

Installation distance of transducers

## 6. Product Specifications

### 6.1 Product Specifications

Screen Size	LCM 128*64 pixels, back light
Button	3-button operation
Comm Interface	RS-485 (Modbus)
Measuring Technology	Transit-time
Analog Output	4~20mA
Pulse Width	Automatic(Pules width 50%)
Pulse Mode	NPN transistor output 32vdc/200mA
Pipe Diameter	DN32–DN150/DN150–DN800
Scope of Measurement	Flow rate 0–15 m/s
Precision	0.6~3 m/s , ±0.2% F.S.(Note1) 3~15 m/s, ±1% O.R.(Note1)
Repeatability	0.5%
Ambient Temperature	-20~60°C
Power Supply	18~32 VDC/100~240VAC
Power consumption	10VA
Inlet Specification	M20*1.5
Protection Level	IP67
EMC	IEC61326

Note 1:

FineTek actual flow testing equipment.

Liquid temperature: 20±10°C , Ambient temperature: 20±5°C

Length of straight pipe section: Upstream side 15 D or more; downstream side 5 D or more.

When in a fixed environment, take note of the linearity value + error range + repeatability value.

The measured result may produce errors due to the type/state of the pipeline, the type of fluid being measured, the temperature of the fluid, etc.

## 6.2 Transmitter Dimension

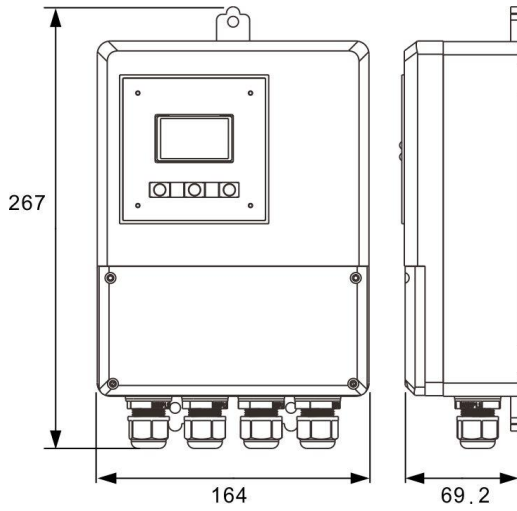

### Transducer S200(DN32~DN150)

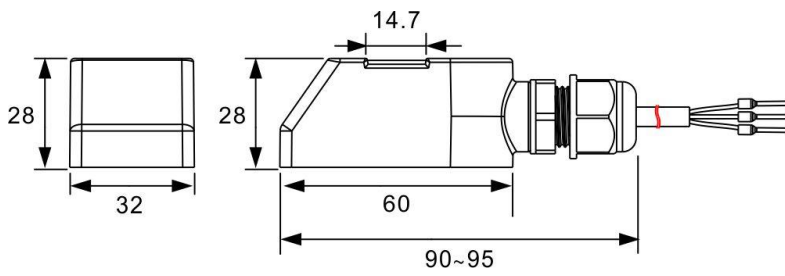

### Transducer S800(DN150~DN800)

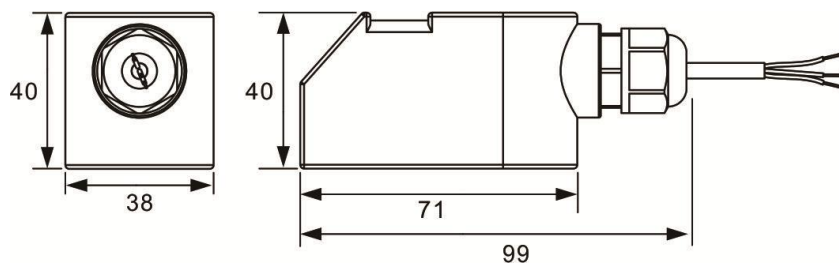

**Stainless Steel Bracket**

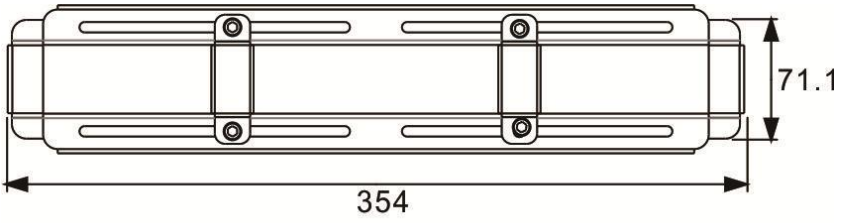

## 7. Parameter Description

### 7.1 Display Interface

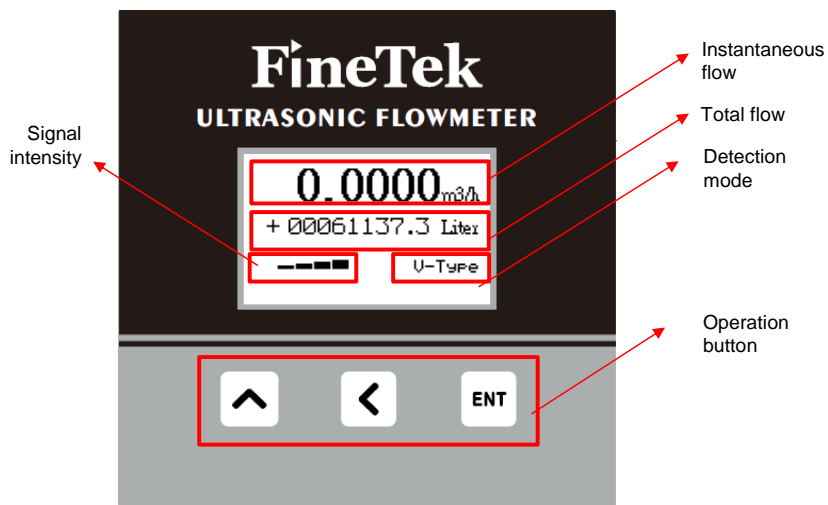

### 7.2 Button Function

Button	Main Screen	Menu Mode	Parameter Setting Interface		
			Read Only	Numeric Edit Mode	List Edit Mode
ENT	Enter menu	Enter submenu		Enter (press and hold)	Enter (press and hold)
←		Go back	Go back	"Left" arrow key	Go back
↑		Menu item (down)		Number: "Plus" button	Option: Page down
ENT+←				Cancel	

### 7.3 Menu Setting Process

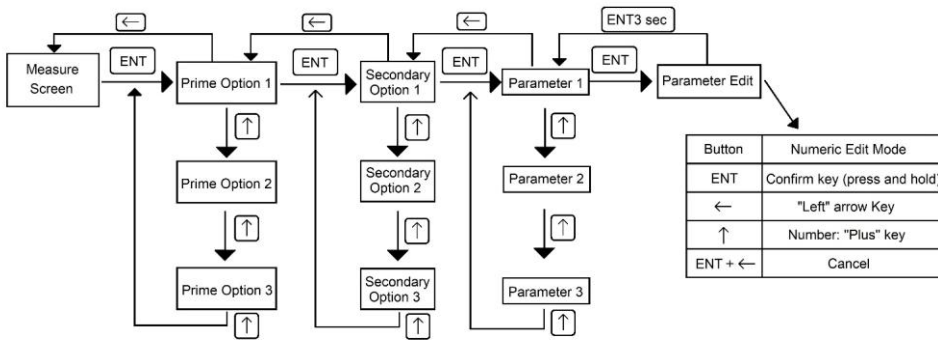

Button	Numeric Edit Mode
ENT	Confirm key (press and hold)
←	"Left" arrow Key
↑	Number: "Plus" key
ENT + ←	Cancel

## 8. Wiring Instructions

### 8.1 Electrical Specifications

Input voltage: DC24V

Input current: 200mA±20%

Observe the following safety tips before using wiring:

The transducer is only allowed to be wired while it is in a power-off state.

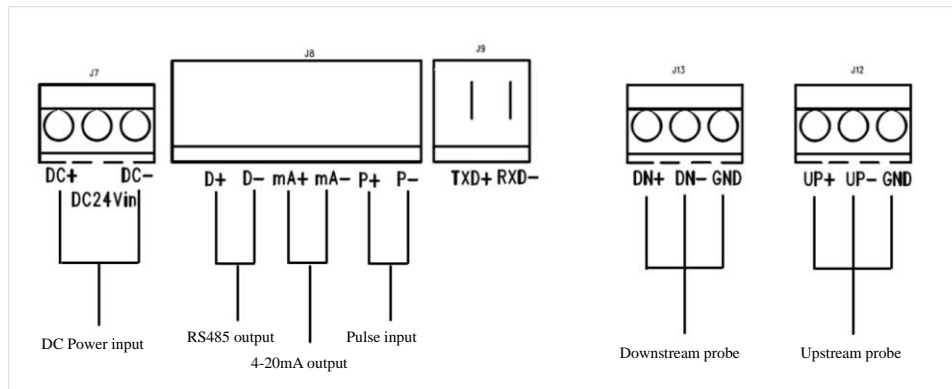

DC+	DC-	DC Power Input			
D+	D-	RS-485 Comm			
mA+	mA-	4-20mA output			
P+	P-	Voltage pulse output			
TXD+	RXD-	Reserved			
DN+	DN-	GND	UP+	UP-	GND
Red wire	White wire	Black wire	Red wire	White wire	Black wire

## 8.2 Electrical Specifications

Input voltage: AC100~240V

Observe the following safety tips before using wiri:

The transducer is only allowed to be wired while it is in a power-off state.

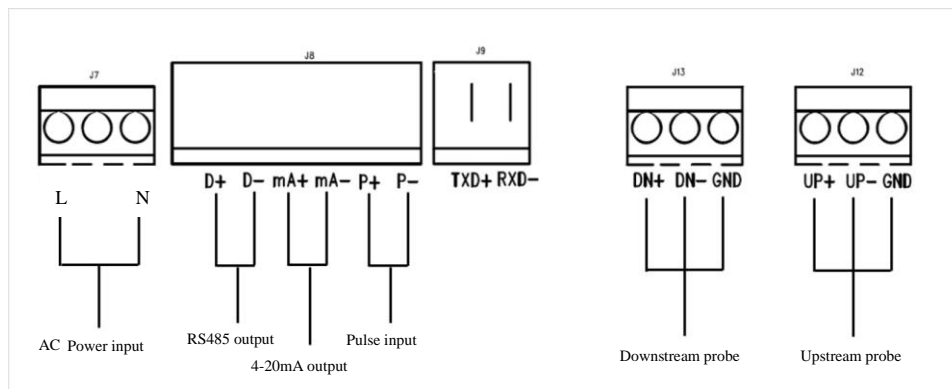

L	N	AC Power Input			
D+	D-	RS-485 Comm			
mA+	mA-	4-20mA output			
P+	P-	Voltage pulse output			
TXD+	RXD-	Reserved			
DN+	DN-	GND	UP+	UP-	GND
Red wire	White wire	Black wire	Red wire	White wire	Black wire

## 9. Installation Instructions

Please refer to the following precautions and methods for use of the product.

- The design, test and electrification of the Flow meter are subject to their respective regulations which users must observe strictly to ensure safe and normal operation of the Flow meter.
- Check the parameters of the pipe and liquid prior for accurate installation of the transducers. Make sure the installation distance of the transducers is correct to ensure the accuracy.

### 9.1 Environmental Safety

Please observe the following requirements to ensure the safety of the personnel and equipment:

- Read this operation manual carefully before selecting the location and installing the Flow meter. Take the safety requirements of the environment where the Flow meter and relevant equipment will be installed into account.
- Only the personnel who have the knowledge of Flow meters are allowed to install, maintain and repair the Flow meter.
- Install the Flow meter, transducer, and transmitter accurately and make sure safe and reliable sealing.
- Take proper measures to avoid electric shock.

### 9.2 Installation Of Circuits

Wiring instructions

- A twin-core rubber insulated cable is recommended for use as the power cable. The outer diameter of the wire shall be 5–7mm.
- The resistance of the power cable connected to a 24VDC power supply shall not be more than 10Ω.
- All the terminal blocks shall be wired with slotted terminals and insulated properly. The wire shall not intrude into the terminal block directly.
- The total impedance of the outgoing cable on the current output terminal shall not be greater than the nominal impedance stated in the specification.
- The pulse or frequency output is usually NPN transistor output. It needs an external power supply.

### 9.3 Precautions

- Prior to the installation, the area of the pipe for installation of the ultrasonic transducers shall be cleaned so thoroughly that the original gloss of the metal is revealed.
- The area where the transducers contact with the pipe shall be cleaned and applied with ultrasonic coupling agent to ensure no air or sand exists on the contact surface. Otherwise, the transmission of the ultrasonic signal may be affected.

## **9.4 Electrification Instructions**

Inspection before electrification

- Make sure the Flow meter, transmitter and transducer are not damaged during the installation.
- Make sure the power supply voltage meets the requirements of the specification.
- The installation distance of the transducers is dependent on the distances between the transmitters.
- Make sure the pipe is full of liquid and the residual air is exhausted completely.

## 10. Installation Steps of Transducers

### 10.1 Selection of the Installation Location

- To avoid that the measurement is affected by the bubbles in the pipe or the pipe is not full of liquid, install the transducers in the section of the pipe where full water is ensured (Figure 1).

The Pipe is Full of Liquid in the Following Cases

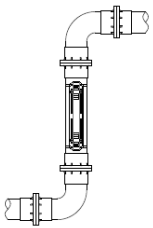

Upward vertical flow

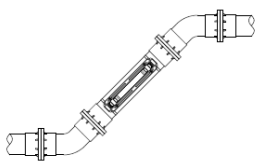

Upward flow at an angle

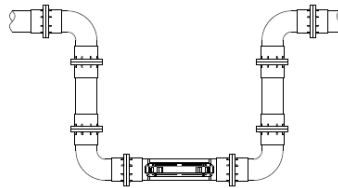

The lowest point in the pipe system

(Fig. 1)

- Do not let air entering the pipe when using the Flow meter. The stability of the measurement will be affected if bubbles exist in the liquid (Figure 2).

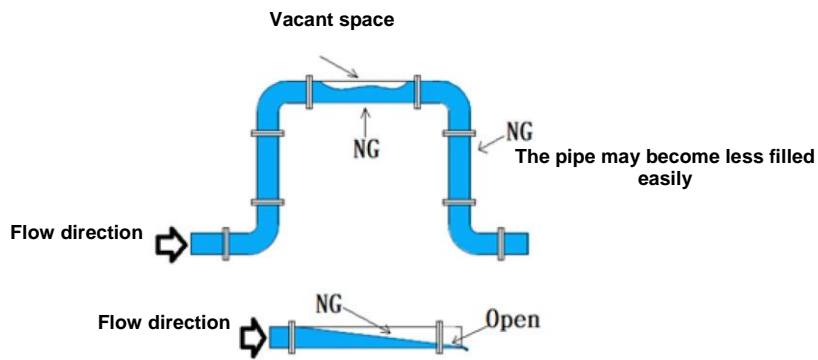

(Fig. 2)

- Install the transducers in the section of the pipe where full water is ensured and don't install them in the section where air or sediment exists (Figure 3).

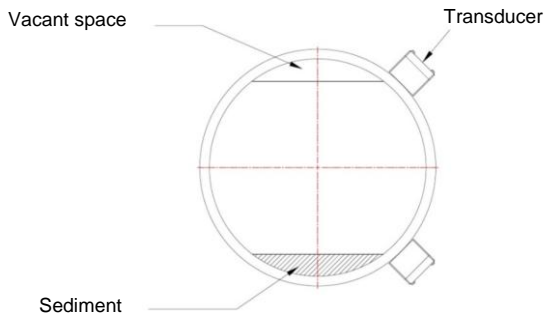

(Fig. 3)

- Do not install the transducer at the pipe fitting or the section of the pipe where weld seam or bead exists. The section of the pipe with a smooth surface is the first choice (Figure 4).

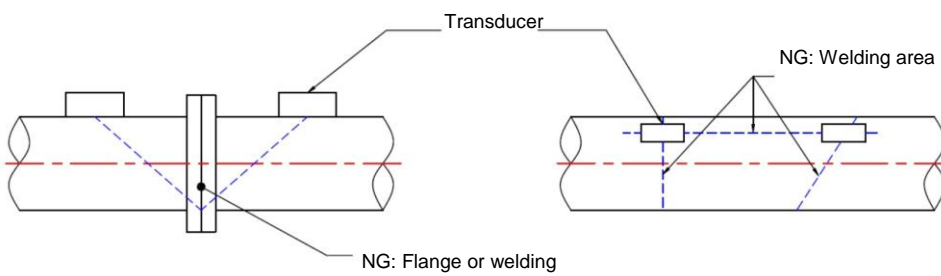

(Fig. 4)

#### Unsuitable locations for Installation of Transducers

- To avoid interference with the detection signal, don't install too many devices nearby.
- The stability of the measurement will be affected if the ultrasonic Flow meter is installed in a liquid of composite properties.
- The installation location of the transducers shall be selected carefully because it may substantially affect the performance of the ultrasonic Flow meter.
- The ambient temperature for the installation of the transducers shall be  $-20^{\circ}\text{C}$  to  $60^{\circ}\text{C}$ . Do not install the transducer in a place close to any heating component.

- The transducers may be deteriorated in performance more quickly if they are exposed to rain or sunshine for a longer period of time. Do not install the transducers in this environment.
- The transmitter, transducer and signal cable of the ultrasonic Flow meter are easily affected by the frequency converter, radio station, TV station, microwave communication station, GSM base station, high-voltage cable, and so on. Therefore, try to keep these facilities away from the transmitter and transducer when you select the installation location for them. The housing of the transmitter and the shielded insulation of the signal cable shall be grounded.
- Do not share the circuit with the frequency converter. An isolated power source shall be used for the transmitter.
- Must pay more attention on mounting method for small-diameter pipelines.

The emitting surface of the sensor must be perpendicular to the central axis. It will lead the sound wave signal dispersed and even no signal being received or the signal got weakened if not complying with such requirement. (Figure 5).

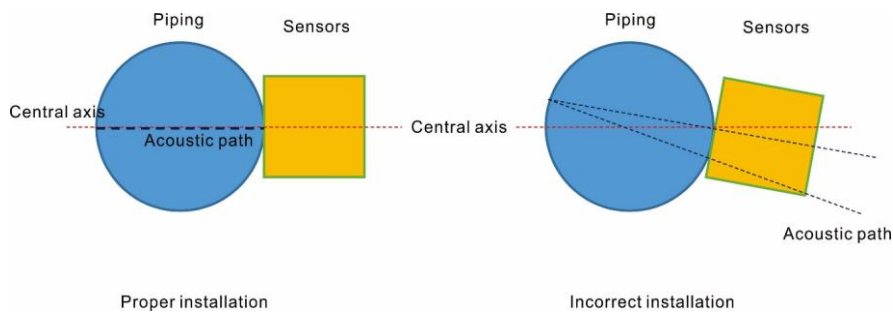

(Fig. 5)

- To improve the accuracy of the measurement, installation of the transducers in the upstream or downstream straight pipe section as shown in the following figure is recommended (Figure 6).  
(D = Outer diameter of the pipe)

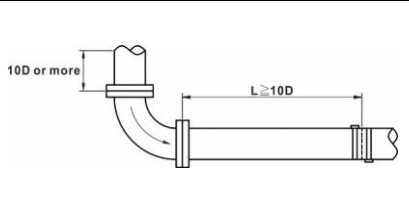
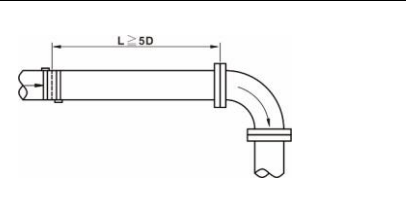
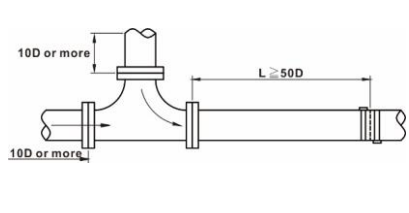
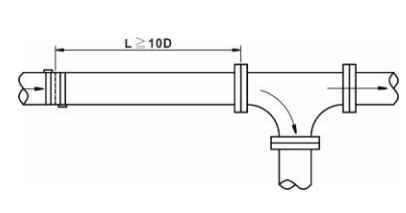
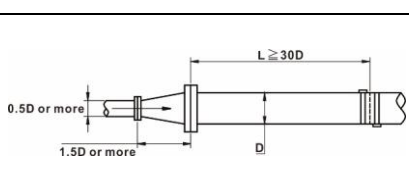
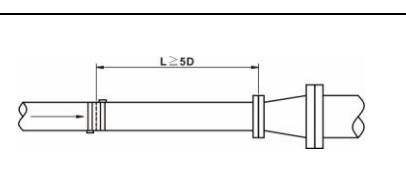
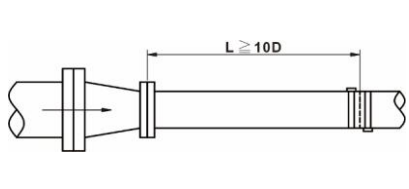
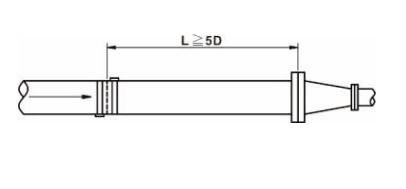
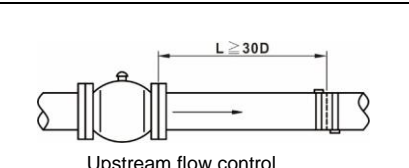
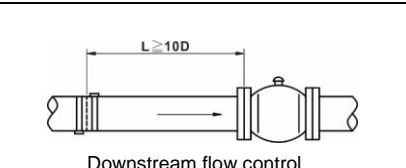
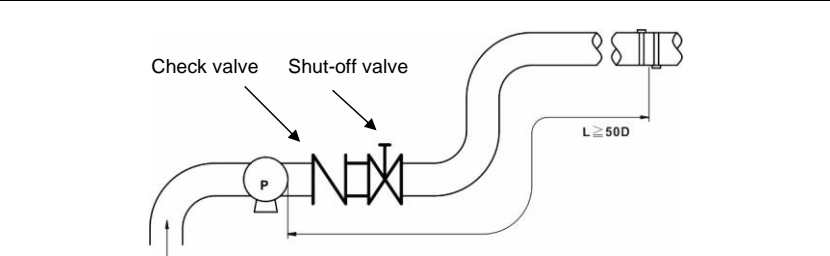
Type	Upstream Straight Section Length	Downstream Straight Section Length
90° bend		
T-type joint		
Divergent pipe		
Convergent pipe		
Control valve	 Upstream flow control	 Downstream flow control
Pump		

(Fig. 6)  
21

## 10.2 Selection of Installation Methods and Settings

(1) Press and hold **ENT** for 3 seconds on the measurement screen to enter the Operation Confirmation.

Click **^** to select Confirm.

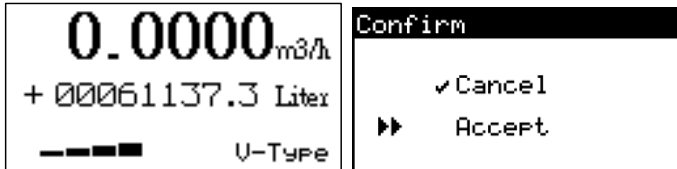

(2) Click **ENT** to enter the Main Menu. Select Installation Set and click **ENT** to continue.

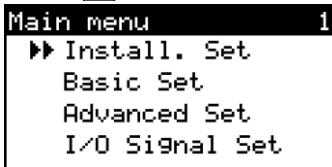

(3) Click **ENT** and select Measure Type (1.1). You can select Water, Sea water or Other. (You need to enter the sound velocity in liquid if Others is selected.)

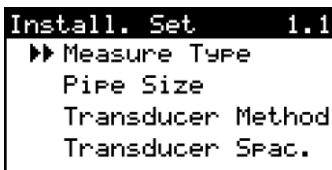

(4) Select Water, Sea water or Other by clicking **^**. Press and hold **ENT** for 3 seconds to save the selection.

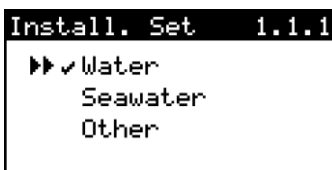

(5) Select "Other" (1.1.3) by clicking Click to enter the sound velocity in liquid. Others is selected for the liquid other than the first two options. If your select this option, you need to enter the sound velocity in liquid in the window under 1.1.3.1.

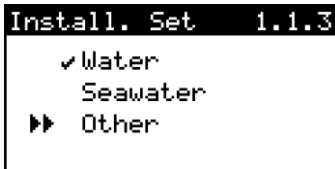

(6) To enter the sound velocity in liquid (1.1.3.1), click to move the position of the number and click to change the number. Press and hold for 3 seconds to save the change. If no change is needed to the number, click simultaneously to return to the pervious page.

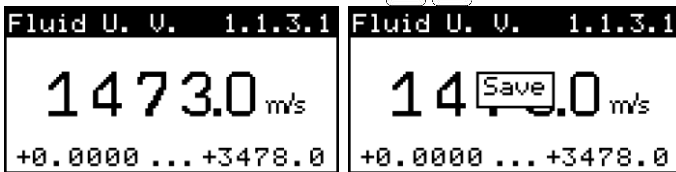

(7) Click return to the Measure Type page (1.1). Click to select Pipe Size (1.2).

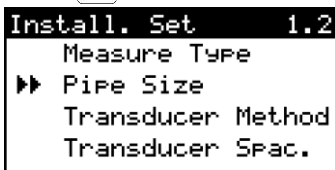

(8) Click to enter Pipe Size and input the parameters by selecting the Pipe Outer Diameter, Pipe Wall Thickness, and Pipe Material options.

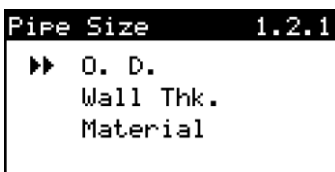

(9) Select Pipe Outer Diameter (1.2.1.1), click **ENT** and enter the outer diameter of the pipe.

Click **<** to move the position of the number and click **^** to change the number. Press and hold **ENT** for 3 seconds to save the change. If no change is needed to the number, click **<** **ENT** simultaneously to return to the pervious page.

※The diameter of the outside pipe could be evaluated by following formular

$$\text{OD} = \text{pipe circumference} / 3.1415926$$

For example : pipe circumference 500mm / 3.1415926 = 159.15mm

```
O. D.      1.2.1.1
060.48 mm
```

(10)Select Pipe Wall Thickness (1.2.2.1), click **ENT** and enter the thickness of the pipe. Click **<** to move the position of the number and click **^** to change the number. Press and hold **ENT** for 3 seconds to save the change. If no change is needed to the number, click **<** **ENT** simultaneously to return to the pervious page.

※Pipe thickness,enter the thickness of the sigle-sided pipe diameter.



```
Wall Thk.  1.2.2.1
005.24 mm
```

(11) Select Pipe Material (1.2.3). Click **ENT** and select Carbon Steel, Stainless Steel, Copper, PVC, or Other.

```
Material    1.2.3.1
▶▶ Carbon stell
✓Stainless steel
  COPPER
  PVC
```

(12) Click **^** to select Other. Click **ENT** and enter the sound velocity in pipe material. Others is selected for the material other than the first four options. If your select this option, you need to enter the sound velocity in pipe material in the window under 1.2.3.5.1.



```
Material    1.2.3.5
✓Stainless steel
  COPPER
  PVC
▶▶ Other
```



(13) Click  to move the position of the number and click  to change the number.

Press and hold  for 3 seconds to save the change.

If no change is needed to the number, click   simultaneously to return to the previous page.



```
Tube U. V. 1.2.3.5.1
3120.4 m/s
```



(14) Click  to return to the Installation Set page. Click  to select Transducer Mounting Method

(1.3). Click  to select Z Type or V Type. Click  to select the mounting method.

Press and hold  for 3 seconds to save the selection.

```
Install. Set 1.3 Transducer Method 1.3.1
Measure Type
Pipe Size
▶▶ Transducer Method
Transducer Spac.
```

(15) Click  to return to the Installation Set page. Click  to select Transducer Type (1.5).

Click  to select S200 DN32–DN150 or S800 DN150–DN800Z Type. Click  to select the

mounting method. Press and hold  for 3 seconds to save the selection.

```
Install. Set 1.5 Transducer Type 1.5.1
Pipe Size
Transducer Method
Transducer Spac.
▶▶ Transducer Type
▶▶ ✓ S200
S800
```

(16) After all the parameters are entered, click  to select Transducer Mounting Spacing (1.4).

Click  to confirm the installation distance parameter for the transducers (1.4.1) to be used for their installation.

```
Install. Set 1.4 Transducer Spac. 1.4.1
Measure Type
Pipe Size
Transducer Method
▶▶ Transducer Spac.
Install distance of
transducer :
+79.5mm
```

### 10.3 V-type Installation of the Transducers

- Make sure the parameters are set correctly for the pipe and liquid before the installation to ensure the accuracy of the installation.
- For the transmitter of the Flow meter, the installation distance of the transducers can be acquired after selecting the type of the installation (V Type) and entering the parameters for the pipe (outer diameter, thickness, material, liquid).
- The section of the pipe to be used for the installation shall be cleaned up and polished in advance.
- V-type installation shall be the first priority for the pipe of 40mm–200mm. The transducers shall be aligned horizontally and their transmission directions shall be arranged against each other (Figure 6).

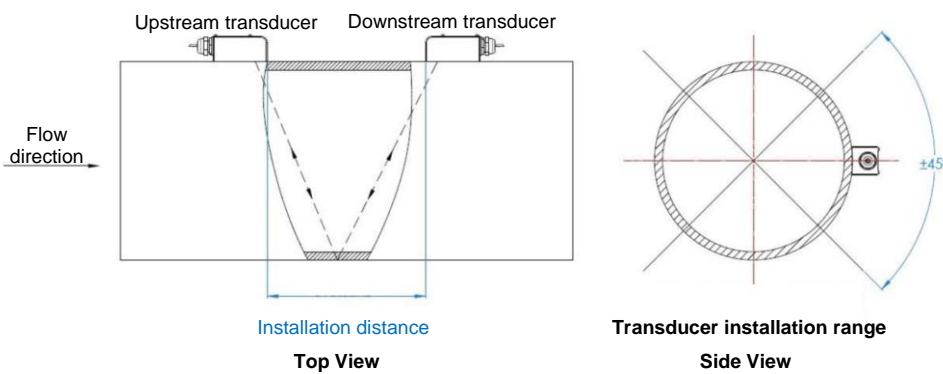

Figure 6

- Have the stainless steel clamp pass through the hole on the bracket of the transducer and wind it onto the pipe.

#### Correct use of metal pipe bundles



Step 1: Pull up the locking screw as shown in the picture



Step 2: Pass out the metal tube bundle from under the locking screw

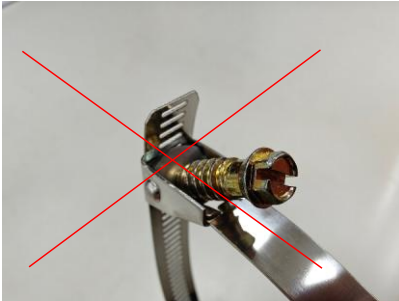

Wrong way of piercing



Step 3: Unfasten the locking screw and use a flat-blade screwdriver to tighten it

- Insert the tail end of the stainless steel clamp in the slot of the clamping apparatus and fixed it firmly. Pull the clamp tightly and pull the fixed head downward to fix the clamp temporarily. Then screw the clamp tightly using a flat-head screwdriver to fix the transducer bracket onto the pipe (Figure 7).

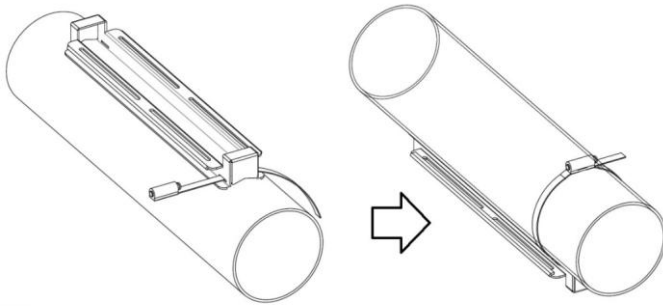

Fix Transducer Bracket  
Figure 7

- Install the upstream and downstream transducers to the direction of the liquid.
- Apply an appropriate amount of the coupling agent (G-40M) to the attaching surfaces of the ultrasonic transducers (Figure 8).

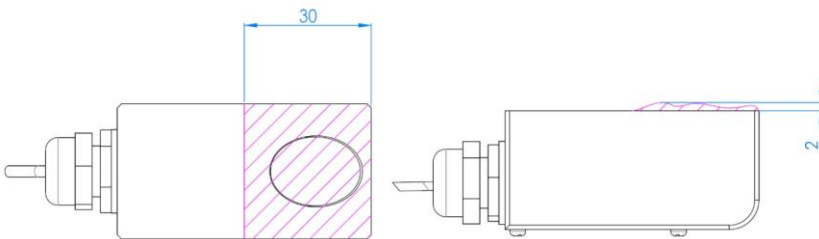

Application of Coupling Agent

Figure 8  
27

Attach the transducers to their respective brackets pursuant to the installation distance and fix the transducers using a fixing piece. Fixing one transducer and installing another one pursuant to the installation distance are recommended (Figure 9).

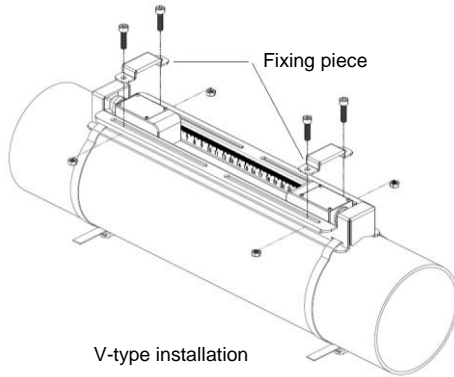

Figure 9

- Connect the cables of the upstream and downstream transducers to the respective upstream and downstream terminals of the transmitter.

#### 10.4 Z-type Installation of the Transducers

- The Z-type installation is recommended if the signal is not detected or the signal intensity is low with the V-type installation.
- Make sure the parameters are set correctly for the pipe and liquid before the installation to ensure the accuracy of the installation.
- For the transmitter of the Flow meter, the installation distance of the transducers can be acquired after selecting the type of the installation (Z Type) and entering the parameters for the pipe (outer diameter, thickness, material, liquid).
- The section of the pipe to be used for the installation shall be cleaned up and polished.

- For the installation, the vertical distance between the two transducers along the axial direction of the pipe is equal to the installation distance and both transducers shall be on the same axial plane. The transducer shall transmit the signal diagonally (Figure 10).

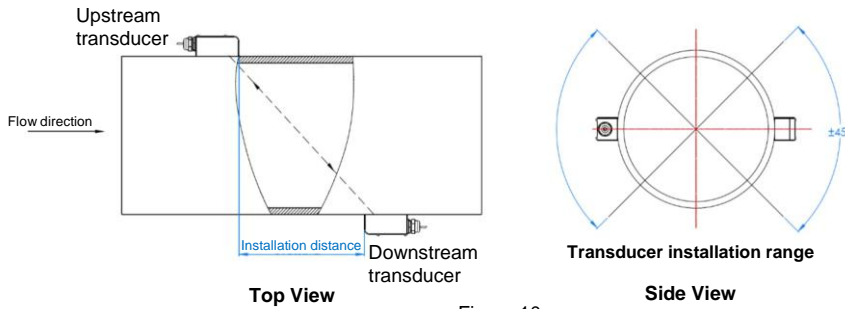
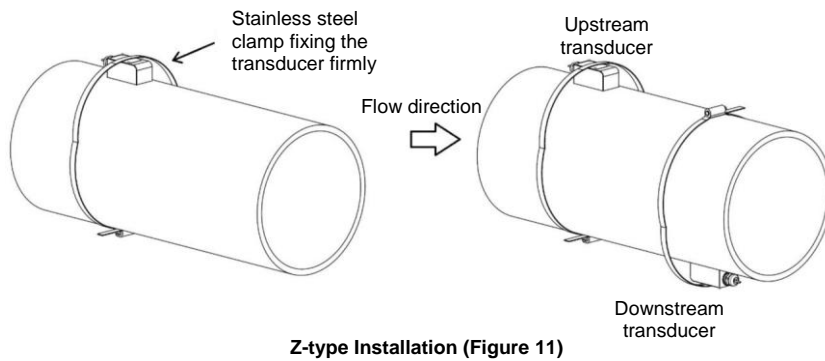

Figure 10

- Install the upstream and downstream transducers to the direction of the liquid.
- Apply an appropriate amount of the coupling agent (G-40M) to the attaching surfaces of the ultrasonic transducers (Figure 8).
- Attach a transducer to the pipe and fix it tightly using the stainless steel clamps. Pull the clamp tightly and pull the fixed head downward to fix the clamp temporarily. Then screw the clamp tightly using a flat-head screwdriver to fix the transducer onto the pipe. Install another transducer pursuant to the installation distance. Fixing one transducer first is recommended (Figure 11).



Z-type Installation (Figure 11)

- Connect the cables of the upstream and downstream transducers to the respective upstream and downstream terminals of the meter head.

# 11. Parameter Settings and Functions

## 11.1 Menu Setting Process

Menu 1	Menu 2	Menu 3	Factory Value	Unit	Setting Range	Function
Installation Set (1)	Measure Type (1.1)	N/A	0. Water	m/s	0. Water 1. Sea water 2. Other	Select the type of the liquid to be measured. If Other is selected, enter the desired page to enter the sound velocity in liquid.
	Pipe Size (1.2)	Pipe Outer Diameter	215.8	mm	xxx.xx	Set the outer diameter of the pipe
		Pipe Wall Thickness	10	mm	xxx.xx	Set the thickness of the pipe (fixed value)
		Pipe Material	PVC	m/s	0. Carbon steel 1. Stainless steel 2. Copper 3. PVC 4. Other	Select the material of the pipe to be measured. If Other is selected, enter the desired page to enter the sound velocity in pipe material
	Transducer Mounting Method (1.3)	N/A	V Type		0. Z Type 1. V Type	Select the mounting method for the transducer
	Transducer Mounting Spacing (1.4)	N/A	Calculation value display	mm	xxx.x	Use the calculation value to display the mounting space for the transducer
Transducer Type (1.5)	N/A			S200 S800	Transducer Type	
Basic Set (2)	Device Tag Num (2.1)	N/A	00001	-	1-65535	The tag number is used for management of the factory at the client end
	Flow Unit (2.2)	N/A	m³/h		"L/m", "L/h", "m³/m", "m³/h", "gal/m", "gal/h", "m³/d"	This unit display is set automatically for the Instantaneous flow. (If a unit is selected for the weight, the flow is multiplied by the density automatically.)
	Flow Span (2.3)	N/A		Flow Rate Unit	(0.1-15.0m/s) * (pipe inner diameter mm/2)² * pi * flow rate unit (000.00)	This flow span setting directly corresponds to the 4-20mA output and the frequency output value
	Direction (2.4)	N/A	0. Forward	-	0. Forward 1. Reverse	Select the direction of the liquid flow
	Total Unit (2.5)	N/A	0.Liter	-	0.Liter 1. gal 2. m	The total flow is set automatically with this unit
	Total Mode (2.6)	N/A	0. Forward	-	0. Forward 1. Reverse 2. Bi-direction	Σ+forward flow measurement, Σ-reverse flow measurement, ΣΔ bi-direction measurement (Δ= forward - reverse)
	Total Reset (2.7)	N/A	0. Cancel	-	0. Cancel 1. Accept	The current displayed total flow is cleared.
Advanced Set (3)	Zero Adj. (3.1)	Auto	0.0000	m/s	-0.5000 to +0.5000	The compensation at the zero point when the pipe is full and there is no flow rate
		Manual				
	K-Factor (3.2)	N/A	Factory calibration value		0.0000-3.0000	Characteristic parameters of the flow transducer; actual value = measured value*k

	Density (3.3)	N/A	1.0000		0.0001–9.9999		
	Low cutoff (3.4)	N/A	0.5	%	0.00–100.00	Look for low cutoff when there is a microflow or vibration in the pipe. (The display and cumulation occur only when the flow rate is greater than this value.)	
	Fwd. Init. (3.5)	N/A	0	Total Unit	0–999999999	Initialize the current total forward flow	
	Rev. Init. (3.6)	N/A	0		0–999999999	Initialize the current total reverse flow	
I/O Signal Set (4)	Damping Time (4.1)	N/A	3	second (s)	0–100	Calculate the average value of the actual flow	
	Pulse Out Mode (4.2)	N/A	0.Pulse NO	-	0.Pulse NO 1.Pulse NC	This shows the initial status of the pulse output connection; the frequency may be used to express the flow rate. (If the frequency is selected, it is expressed depending on the flow rate.) Pulse No and Pulse NC show the high and low potential status of the total output	
	Pulse Out Unit (4.3)	N/A	0.1 L	Unit/pulse	0.001–100 (Liter, gal, m)	The flow represented by each pulse can be set.	
	Curr. Mode (4.4)	N/A	4-20	-	4-20,0-20	Select the current output mode	
	4mA Fine-Tune (4.5)	N/A	0	count	-5000–5000	Adjust the reference value for 4mA output	
	20mA Fine-Tune (4.6)	N/A	0	count	-5000–5000	Adjust the reference value for 20mA output	
	Alarm Set (5)	Curr. Func. (5.1)	N/A	None	-	None, Empty Tube, System Alarm	Select the current alarm function
Alarm Curr. (5.2)		N/A	3.6	mA	3.6,3.8,20.5,22	Set the output current when alarm occurs	
System Set (6)	Language (6.1)	N/A	English	-	English, Traditional Chinese, Simplified Chinese	System display language	
	System Info. (6.2)	N/A					
	Self-Test (6.3)	N/A					
	Modbus Comm. (6.4)	Modbus ID	1	N/A		1–255	Basic communication setting
		BaudRate	9600	BPS		1200, 2400, 4800, 9600, 19200, 38400, 57600, 115200	
		Parity	None	N/A		none, odd, even	
		Stop bit	1	N/A		1, 2	
Recovery Default (6.5)	N/A	Cancel	N/A		Cancel Accept		
LCM Contrast Brightness (6.6)	N/A	50%	%				
Simulation (7) (Return to the normal mode upon leaving the menu.)	Flow Speed (7.1)	N/A	0	m/s	-15 to +15	Simulate the flow rate to have the system react correspondingly. (Return timing is not available on the menu.)	
	Flow Rate (7.2)	N/A	0	Flow unit	0–max. value of the given diameter	Simulate the flow to have the system react correspondingly. (Return timing is not available on the menu.)	
	Output Curr. (7.3)	N/A	4mA	mA	3.6–22	Only the current output port reacts. (Return timing is not available on the menu.)	
	Output Freq. (7.4)	N/A	2	Hz(pulse/sec.)	2–8000	The pulse port reacts in frequency output correspondingly. (Return timing is not available on the menu.)	
Product Info (8)	F.W. Version (8.1)	N/A					

已註解 [A1]: 建議保留原文, 若也要翻譯成英文, 請用 Traditional Chinese, Simplified Chinese

### 13. Error Message and Troubleshooting

Abnormality	Cause of Failure	Solution
Unstable Instantaneous Flow	Tube is not full.	<ol style="list-style-type: none"> <li>1. Install sensor horizontally, not vertically.</li> <li>2. Extend damping time.</li> <li>3. Ensure that the liquid fills up the pipe fully.</li> </ol>
	Uneven flow distribution rate.	<ol style="list-style-type: none"> <li>1. Install sensor at a section of pipe with sufficient space.</li> <li>2. Avoid installing directly behind the valve.</li> <li>3. Extend damping time.</li> </ol>
Instantaneous flow does not change from zero.	No actual flow.	Confirm status of the switch, and whether the pipe is blocked.
	There is flow, but slower than the set speed.	Adjust the setting for restricting flow rate.
	No signal received.	Refer to "no signal received" topic below.
No signal received (the indicator light at the bottom left side of the LCM flashes sequentially).	Sensor is not properly fixed to the pipe.	<ol style="list-style-type: none"> <li>1. Confirm that the installation distance is correct.</li> <li>2. Confirm that couplant has been applied.</li> </ol>
	Tube not full.	<ol style="list-style-type: none"> <li>1. Install sensor horizontally, not vertically.</li> <li>2. Ensure that the liquid in the pipe is full.</li> </ol>
	Affected by foreign objects or air bubbles.	Install at another location.
	The surface or inside of the pipe affects and hinders the measurement signal.	<ol style="list-style-type: none"> <li>1. Install at another location.</li> <li>2. If the pipe surface rusty or dirty, avoid this area and reinstall the sensor.</li> <li>3. If there are seams on the pipe, avoid this area and reinstall the sensor.</li> </ol>
	Sensor is damaged.	Please contact our customer service.
LCM has no display or backlight.	Not connected to power supply.	Confirm whether the power line is connected incorrectly or is disconnected.

## 12. MODBUS Communication Protocol

Address (Hex)	Address (Dec)	Variable Name	Data Type	Unit	Range	Definition	Authority
0x1000	4096	gt_modbus_slave_fine_tek_id[0]	UINT8	N/A		"IF"	Read only (Header)
0x1001	4097	gt_modbus_slave_fine_tek_id[2]	UINT8	N/A		"EN"	Read only (Header)
0x1002	4098	gt_modbus_slave_fine_tek_id[4]	UINT8	N/A		"T-"	Read only (Header)
0x1003	4099	gt_modbus_slave_fine_tek_id[6]	UINT8	N/A		"KE"	Read only (Header)
0x1004	4100	PFC_PRODUCT_TYPE	UINT16	N/A		"FM"	Read only (Header)
0x1005	4101	PFC_PRODUCT_NUMBER	UINT16	N/A		0x0001	Read only (Header)
0x1006	4102	PFC_PRODUCT_VERSION	UINT16	N/A		0x0001	Read only (Header)
0x1007	4103	PFC_PRODUCT_DATE	UINT32	N/A		0x20200731 = 2020/7/32	Read only (Header)
0x1008	4104						
0x1009	4105	PFC_PRODUCT_TIME	UINT32	N/A		0x082712 = 8:27:12	Read only (Header)
0x100A	4106						

Address (Hex)	Address (Dec)	Variable Name	Data Type	Unit	Range	Definition	Authority
0x1034	4148	PFC_FlowRate_Main_Val	FLOAT64			Instant flow rate	Read only
0x1035	4149						
0x1036	4150						
0x1037	4151						
0x1038	4152	PFC_BASIC_SET_FLOW_RATE_UNIT	UINT16	N/A	0 : PFC_FLOW_UNIT_L_m 1 : PFC_FLOW_UNIT_L_h 2 : PFC_FLOW_UNIT_m³_m 3 : PFC_FLOW_UNIT_m³_h 4 : PFC_FLOW_UNIT_gal_m 5 : PFC_FLOW_UNIT_gal_h 10 : PFC_FLOW_UNIT_m³_d	Instant flow rate unit default = 3	Read only
0x1039	4153	PFC_FlowTotal_FRAM_FWD_VAL	FLOAT64	m³		Forward accumulated flow capacity	Read only
0x103A	4154						
0x103B	4155						
0x103C	4156						
0x103D	4157	PFC_FlowTotal_FRAM_REV_VAL	FLOAT64	m³		Backward accumulated flow capacity	Read only
0x103E	4158						
0x103F	4159						
0x1040	4160						
0x1041	4161	PFC_FlowTotal_FRAM_BI_DIR_VAL	FLOAT64	m³		Two-way accumulated flow capacity	Read only
0x1042	4162						
0x1043	4163						
0x1044	4164						
0x1045	4165	gff_flowrate_span_value	FLOAT64	m/s		Instant flow span value	Read only
0x1046	4166						
0x1047	4167						
0x1048	4168						

Address (Hex)	Address (Dec)	Variable Name	Data Type	Unit	Range	Definition	Authority
0x104D	4173	gl_flowtotal_fwd_val-low	INT32	m³	0 ~ 999999999	Forward accumulated flow capacity	Read only
0x104E	4174	gl_flowtotal_fwd_val-high					
0x104F	4175	gl_flowtotal_rev_val-low	INT32	m³	0 ~ 999999999	Reversed accumulated flow capacity	Read only
0x1050	4176	gl_flowtotal_rev_val-high					
0x1051	4177	gl_flowtotal_bidi_val-low	INT32	m³	0 ~ ±999999999	Bi-directional accumulated flow capacity	Read only
0x1052	4178	gl_flowtotal_bidi_val-high					
0x1053	4179	gf_Flowrate_main_val-low	FLOAT32	N/A	0 ~ ±99999	Instant flow rate	Read only
0x1054	4180	gf_Flowrate_main_val-high					
0x1055	4181	gl_flowtotal_fwd_rollover_times	INT32	times	0 ~ 999999999	Increase max.forward accumulated flow volume's digit count	Read only
0x1056	4182						
0x1057	4183						
0x1058	4184	gl_flowtotal_rev_rollover_times	INT32	times	0 ~ 999999999	Increase max.reversed accumulated flow volume's digit count	Read only
0x1059	4185	gl_flowtotal_bidi_rollover_times	INT32	times	0 ~ ±999999999	Increase max.bi-directional accumulated flow volume's digit count	Read only
0x105A	4186						

Address (Hex)	Address (Dec)	Variable Name	Data Type	Unit	Range	Definition	Authority
0x107E	4222	PFC_BASIC_SET_MOTHOD_VAL	UINT16	N/A	1~2	Installation type Z=1, V=2, (Default = 2)	Read /Write
0x107F	4223	PFC_BASIC_SET_DEVICE_TAG_NUM	UINT17	N/A	1~65535	Basic setting / ID number Default = 1	Read /Write
0x1088	4232	PFC_BASIC_SET_TUBE_OUTSIDE_DIAMETER	FLOAT32	mm		Pipe outer diameter Default = 60.48	Read /Write
0x1089	4233						
0x108A	4234	PFC_BASIC_SET_TUBE_THICKNESS	FLOAT32	mm		Pipe thickness Default = 5.24	Read /Write
0x108B	4235						
0x108E	4238	PFC_BASIC_SET_TUBE_ULTRASONIC_VELOCITY	FLOAT32	m/s		Pipe sound velocity Default = 3120.432397	Read /Write
0x108F	4239						
0x1090	4240	PFC_BASIC_SET_FLUID_ULTRASONIC_VELOCITY	FLOAT32	m/s		Fluid sound velocity Default = 1473	Read /Write
0x1091	4241						
0x10B0	4272	PFC_SAVE_SYSTEM_VAR_TO_EEPROM	UINT16	N/A	0:Idel, 1:Save	Save system parameters to User EEPROM	Read /Write
0x10B1	4273	PFC_ENG_MODE_SAVE_SETTING	UINT16	N/A	0:Idel, 2:Save	Save system parameters to factory EEPROM	Read /Write
0x10B2	4274	PFC_LOAD_FIRMWARE_SETTING	UINT16	N/A	0:Idel, 2:Save	Load Firmware default to User&Factory EEPROM	Read /Write
0x10C0	4288	PFC_ADVANCED_SET_FWD_TOTL_INIT	FLOAT64			Forward accumulated flow rate start value	Read /Write
0x10C1	4289						
0x10C2	4290						
0x10C3	4291						

0x10C4	4292	PFC_ADVANCED_SET_REV_T OTAL_INIT	FLOAT64			Backward accumulated flow rate start value	Read /Write
0x10C5	4293						
0x10C6	4294						
0x10C7	4295						
0x10E5	4325	PFC_BASIC_SET_FLOW_RATE_UNIT	UINT16		0 : PFC_FLOW_UNIT_L_m 1 : PFC_FLOW_UNIT_L_h 2 : PFC_FLOW_UNIT_m <sup>3</sup> _m 3 : PFC_FLOW_UNIT_m <sup>3</sup> _h 4 : PFC_FLOW_UNIT_gal_m 5 : PFC_FLOW_UNIT_gal_h 10 : PFC_FLOW_UNIT_m <sup>3</sup> _d	Instant flow rate unit default = 3	Read /Write
0x10E7	4327	PFC_BASIC_SET_FLOW_DIR	UINT16		0: forward 1: backward	Basic setting/Flow direction	Read /Write
0x10E8	4328	PFC_BASIC_SET_FLOW_TOTAL_UNIT	UINT16		0:Liter 1:gal 2:m3	Basic setting/ Accumulated flow capacity unit	Read /Write
0x10E9	4329	PFC_BASIC_SET_TOTAL_MODE	UINT16		0: forward 1: backward 2: two-way	Basic setting/ Accumulated flow capacity mode	Read /Write
0x10EA	4330	PFC_BASIC_SET_TOTAL_RESET	UINT16		0: cancel 1: confirm	Basic setting/ Accumulated flow capacity reset	Read /Write
0x10EB	4331	PFC_IO_SIGNAL_SET_DAMPING_TIME	UINT16	Sec	000--100 (Default:6)	Output/Input signal setting / Input signal average time	Read /Write
<b>Address (Hex)</b>	<b>Address (Dec)</b>	<b>Variable Name</b>	<b>Data Type</b>	<b>Unit</b>	<b>Range</b>	<b>Definition</b>	<b>Authority</b>
0x1110	4368	PFC_SYSTEM_SET_MODBUS_ID	UINT16		1-255	System setting/ MODBUS communication/Modbus ID default = 1	Read /Write
0x1111	4369	PFC_SYSTEM_SET_MODBUS_BAUDRATE_SEL	UINT16	BPS	0:1200 1:2400 2:4800 3:9600 4:19200 5:38400 6:57600 7:115200	System setting/ MODBUS communication/ BaudRate default = 3 (9600 bps)	Read /Write
0x1112	4370	PFC_SYSTEM_SET_MODBUS_PARITY_SEL	UINT16	N/A	0: None 1: Even 2: Odd	System setting/ MODBUS communication/ Parity default = 0 (Parity None)	Read /Write
0x1113	4371	PFC_SYSTEM_SET_MODBUS_STOP_BITS_SEL	UINT16	Bit	0: 1 1: 2	System setting/ MODBUS communication/ Stop bit default = 0 (1 stop bit)	Read /Write
0x1120	4384	PFC_ADVANCED_SET_K_FACTOR	FLOAT64			Advanced/ K factor	Read /Write
0x1121	4385						
0x1122	4386						
0x1123	4387						
0x1124	4388	PFC_ADVANCED_SET_K1_FACTOR	FLOAT64			Advanced setting/On-site environment compensation	Read /Write
0x1125	4389						
0x1126	4390						
0x1127	4391						

0x112C	4396	PFC_ADVANCED_SET_LOW_C UTOFF	FLOAT64		+0.0000~ +1.0000 (Default:0.005)	Advanced setting/Low rate shield default = 0.005	Read /Write
0x112D	4397						
0x112E	4398						
0x112F	4399						
0x1130	4400	PFC_ADVANCED_SET_ZERO_ ADJ	FLOAT64			Basic setting/Zero point adjustment default = 0.0	Read /Write
0x1131	4401						
0x1132	4402						
0x1133	4403						
0x1134	4404	PFC_ADVANCED_SET_VELOC ITY_ZERO_ADJ	FLOAT64			Basic setting/Zero point adjustment default = 0.0	Read /Write
0x1135	4405						
0x1136	4406						
0x1137	4407						
0x1176	4470	gf_snr_disp_level	FLOAT32			Signal strength ratio	Read /Write
0x1177	4471						
0x1178	4472	gf_snr_prev_disp_level	FLOAT32			Signal strength ratio	Read /Write
0x1179	4473						