



## Measuring Systems for Solids



+886-2-2269-6789



[www.fine-tek.com](http://www.fine-tek.com)  
[info@fine-tek.com](mailto:info@fine-tek.com)

## ◆ PRODUCT INDEX ◆

01

**HUMY3000 / HUMY3019 / HUMY300**  
Continuous inline moisture  
measuring system for bulk materials



**MF3000**  
Mass flow measurement  
for bulk materials

08

12

**FS 510M**  
Continuous flow monitoring  
for bulk materials



**FS 700E / FS 710E**  
Dust monitoring for filter break

14

18

**LC 510M**  
Contactless level monitoring  
for bulk material



20

**ORDER INFORMATION**  
HUMY3000 / HUMY3019 / HUMY300  
MF3000 / FS 510M / FS 700E / FS 710E / LC 510M

# HUMY 3000/3019/300

## Continuous inline moisture measuring system for bulk materials



### Application

The moisture in solids is an important parameter which strongly influences the quality of the product and the efficiency of the production. However, the common measurement method is still the examination of samples in the laboratory, which is time-consuming and the results of which are only available with a delay.

Our inline moisture measurement system HUMY 3000 is the better alternative. It allows immediate reaction to moisture changes, e.g. by regulating a dryer, an automatic humidification system or other process parameters. It is equipped with a local control unit, and can be operated with or without connection to a PLC.

### Scope of use

- Animal food
- Building materials
- Chemical industry
- Coal processing
- Fertilizer industry
- Food industry
- Metal processing
- Pharmaceuticals
- Plastics
- Power plants
- Pulp and Paper
- Recycling
- Steel industry
- Tobacco
- Wood
- etc.

## Application

The moisture in solids is an important parameter which strongly influences the quality of the product and can increase the economic efficiency of a production fundamentally. HUMY series is in many processes successfully in use, e.g. for sugar, tobacco, grain, malt, flour, coal, sand, wood shavings, dried food, fertilizer, powder, pigments, plastic granules.

As installation places conveyor belts, screw conveyors, silos, funnels are particularly suitable. The In-Line moisture measurement is also possible in batch processes.

At the measuring the relative permittivity and the high-frequency recession of the solid is measured in the high-frequency range.

The measurement procedure makes a short and simple calibration as well as a high precision of up to 0.1% possible. The measuring probe transmits the data digitally. This makes the measurement assignment disturbance insensitive and allows a distance of the sensor to the end judging unity up to 1000 m.

The system supervising itself has an integrated data logger besides an automatic compensation of temperature and ageing drift, digital and alarm exits. On the LC display are represented the measurement analogously and digitally.

A simple control and parameter setting of all function is carried out via soft keys. For product or process changes different product parameters can be stored.

## Main Benefits

- No samples for the laboratory necessary
- Saving of energy costs
- Improvement on the product quality
- Very short amortization time
- High selective sensitiveness
- High measuring speed
- Precision better than 0.1%  
(Depends on product)
- Easy and economical installation
- Fast and simple calibration
- Optional ATEX-Version for Zone 20 and Zone 0

## Examples for Installations

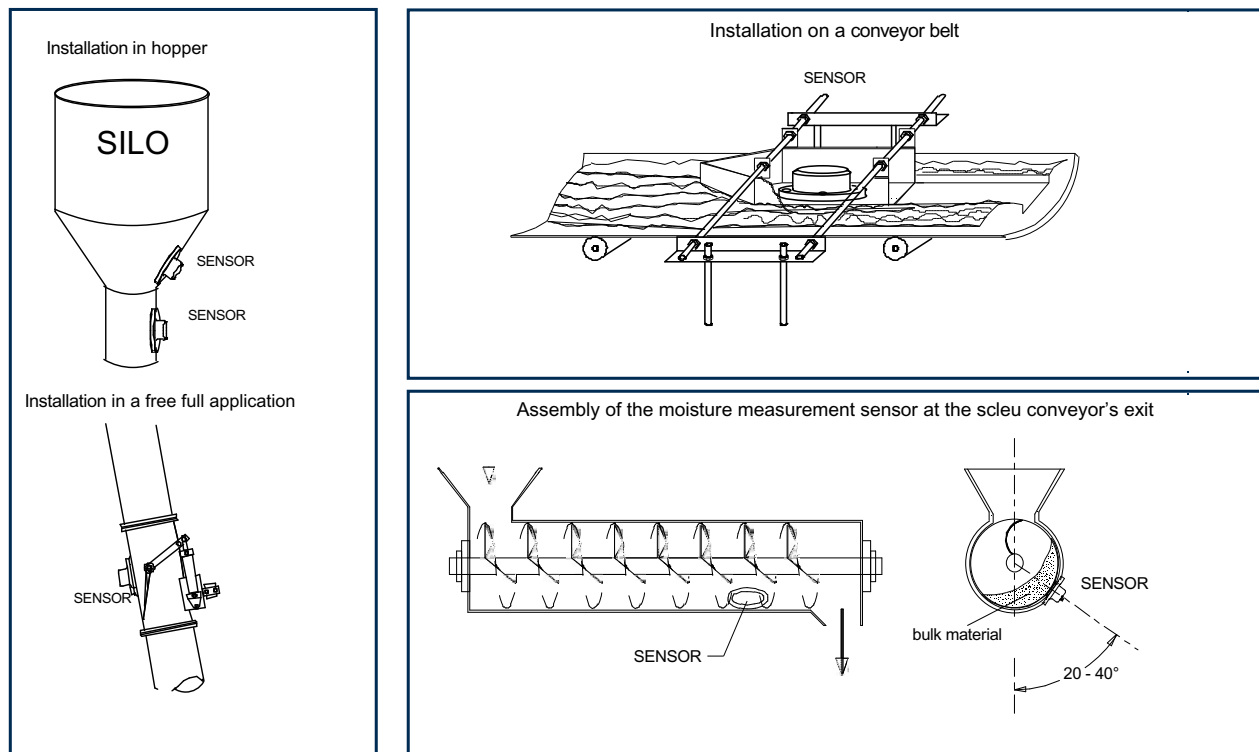

## Application examples of successfully measured products

### Chemicals and pharmaceutical

Fertilizer, plastics, phosphate, granules, absorber materials, melamine, powders, tablets, pasta, foils, salt, potash washing-powder, styrofoam, synthetic material, PVC, acryl pigments

### Food- and animal food industry

Grain, rape, sunflower seeds, sugar beets, potato products, flour, starch, milk powder, yeast, bean oil production, casein, gluten, gelatine, malt, hops soya, corn, lenses rice, pasta, beans confectionery, cereals, food means, fish meal, dried food

### Steel industry and power plants:

Ash, Aluminium oxide, iron, cole, coal, coal dust, coke, hydraded lime, sand, quartz, bricks (raw material), ceramic (raw material), gypsum

### Wood and paper industry:

Cellulose, saw dust, wood chips, wood pellets

### Construction material industry:

Cement, iron-II-sulfat, sand, quartz, gypsum, hydraded lime, limestone powder, bentonite, bricks (raw material), ceramic (raw material)

### Other:

Tobacco, nuts, coffee and cacao beans, biscuits, cotton, leather, spices, blossoms

## Application



Sand



Animal feed



Mounting in discharge screw  
(wood-fired power plant)



Grain



Cereals



Coal

## Humy 3000 Technical Data Measuring Unit



Construction E



Construction T



Construction S

Construction F	Field-/wall-mounting housing, B 265 x H 240 x T 250, weight approx. 6.5 kg, with sight-door IP6
Construction T	Desk-housing B 236 x H 132 x T 330mm, weight approx. 4.5 kg, Option panel housing
Construction E	19"-plugin 3HE / 42 TE, weight approx. 2 kg
Construction S	Panel housing with sight door B270 x H183 x T223, IP 58
Indication	1/4 VGA-LC-Display 100 x 77 mm, 320 x 240 colour-pixel. For analogue and digital measurement representation
Display	Date, time, kind of product, temperature, value of residual, moisture or value of dehydrated substance, Min- and Max-alarm values, analog bar graph indication, dragging pointer width of deviation of measuring value with intensified indication of width of deviation of measuring value, digital indication and description of Min-/Max-limit values and the softkeys
Digital resolution	20 Bit for 0-85,0% moisture and 15 - 100% dry substance
Measuring range moisture	Min. 0.02 – 0.10%, max. 0.02 – 90.00%, with 1-,2- or 3 digits behind the point
Measuring range temp.	Span min.: 0-5° C, Span max.: 0-120° C
Accuracy	Max. 0.1 % in accordance to material to be measured
Handling	Foil-keyboard with each 4 pcs. 10-Block + Function keys + Softkeys
Averaging time	0-999 sec.
Memory	User-memory for storage of parameters of 24 different products.
Data logger	Storage of historical values up to 10 years. Real time clock for measurement record keeping.
Relay output	Normally opened and normally closed contact for each Min- and Max-alarm relay Contact load: 30VDC or 62.5 VAC
Analog output	Measuring value of residual moisture or dehydrated substance 0/4-20 mA (load 750 Ω. measuring value of product temperature, 0/4-20 mA, max. load 750 Ω.
Analog input	mA- and PT 100- input
Digital output	2x galvanic isolated, 24 V open-drain(max. 50mA)
Digital input	2x galvanic isolated, active signals (8-36 V)
Interface	RS 232 with connection for RxD, TxD, OV and RS-485
Power supply	230 V AC / 115 V AC or 24 V AC/DC All supplies can be available simultaneously (230 VAC and 24 VAC/DC or 115 VAC and 24 VAC/DC).

## Technical Data Moisture Sensor

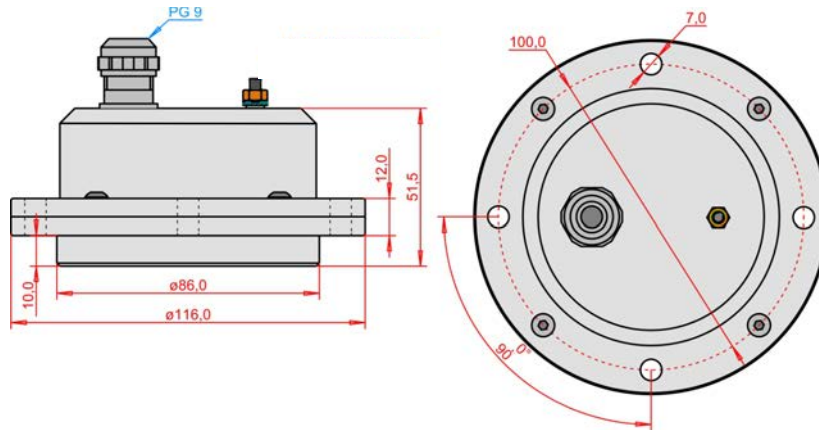

FMS 400 K	Measuring surface POM
FMS 400 C	Measuring surface ceramic
FMS 400 T	Measuring surface PTFE
Housing	Stainless steel 1.4307
Weight	Approx. 1.05 kg
Protection class	IP 67 according to EN 60529
Connection cable	Shielded 4-wires cable, 0.25 up to 0.5 mm <sup>2</sup>
Cable length	max. 1000 m with 0.75 mm <sup>2</sup>
Process-temp.	-10° ~ 90° C 140°C with cooling
Storage temp.	-10° ~ 80° C
Response time	Approx. 1 seconds
Power consumption	0.4 Watt
Signal	RS 485
Pressure resistance	Up to 6 bar



## Humy 3019 Technical Data Measuring Unit

Construction F	Field-/wall-mounting housing, B 265 x H 240 x T 250, weight approx. 6.5 kg, with sight-door IP65
Construction T	Desk-housing B 236 x H 132 x T 330mm, weight approx. 4.5 kg, Option panel housing
Construction E	19"-plugin 3HE / 42 TE, weight approx. 2 kg
Construction S	Panel housing with sight door B270 x H183 x T223, IP 58
Perm. temp.	-10° till + 60°C
Storage temp.	-10° till + 70°C
Perm. humidity while operation	10% till 95% (without condensation)
Digital resolution	20 Bit for 0-85 % moisture and 15 - 100% dry substance
Measuring range temp.	Span min.: 0-5° C, Span max.: 0-120° C
Handling	Via Software Hu-Config
Accuracy	max. 0,02 % depending on the measured material
Averaging time	0-999 sec.
Memory	User-memory for storage of parameters of 24 different products.
Data logger	Storage of historical values up to 10 years. Real time clock for measurement record keeping.
Relay output 2X	Normally opened and normally closed contact for each Min- and Max-alarm relay Contact load: 30VDC or 62.5 VAC
Analog output 2X	0/4-20 mA with a max. load of 750 Ω or 0/2-10 V with a min. load of 50 kΩ Measuring value of residual moisture /dehydrated substance and product temperature
Analog input	mA- and PT 100- input for additional compensation
Digital output 2X	Galvanic isolated, 24 V open-drain(max. 50mA)
Digital input 2X	Galvanic isolated, active signals (8-36 V)
Interface	RS-232 (front socket connection to PC) RS-485 (half-duplex)
Power supply	230 V AC / 115 V AC or 24 V AC/DC
Power consumption	Max. 6W

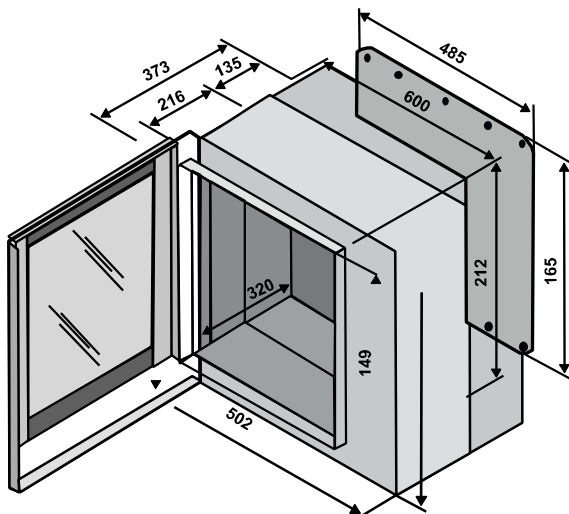

Construction F



## Humy 300 Technical Data Evaluation Unit

Housing	DIN-Rail Mounting
Material	PBT
Dimensions	22.5 mm x 114.5 mm x 99.0 mm (without clamps)
Protection class	IP20
Accuracy	Better than 0.1% (depending on product)
Weight	250 g
Perm. temp.	-10° ~ 60°C
Storage temp.	-10° ~ 60°C
Perm. humidity while operation	10% ~ 95% (without condensation)
Digital resolution	20 Bit for 0 - 85% moisture and 15 - 100% dry substance
Measuring range moisture	Min. 0,000 - 0,100%, max. 0,0 - 90%, with 1-,2- or 3 digits behind the point
Handling	Via Software Hu-Config
Averaging	0-999 sec.
Memory	User-memory for storage of parameters of 24 different products.
Relay output	Nominally opened and nominally closed contact for max-alarm relay Contact load: 30VDC or 62,5 VAC
Analog output	Measuring value of residual moisture or dehydrated substance 0/4-20 mA, load 500 Ω.
Digital input	2x galvanic isolated, active signals (8-36 V)
Interface	USB-Interface for Hu-Config; RS 232 with connection for Rx/D, Tx/D, OV; RS 485
Software	Hu-Config (included)
Power supply	24 V AC/DC



# MF 3000

Mass flow measurement for bulk materials



## Function

Our solid flow meter MF 3000 is designed for flow measurement in metallic pipes from a few kg/h to many t/h. The system is suitable for on-line measurements of powders, dusts, pellets, and granules from 1 nm up to 20mm cm in pneumatic or free fall conditions.

The measurement principle of the MF 3000 is based on the physical Doppler-Effect, whereas the sensor generates a uniform field in the microwave frequency range inside the pipe. These microwaves are being reflected by particles passing through the pipe. Calculation of frequency and amplitude changes allows for accurate determination of solid flow. Non-moving particles like dust accumulation are excluded from the calculation.

The installation is simple and cost effective via a welded branch, through which the sensor is screwed flush to the inside of the pipe. The sensor is connected to a DIN-rail mounted transmitter with 4...20 mA, RS232 and RS485 output. The calibration is easy by using our MF-SMART software and a reference flow value.

## Main Benefits

- For pneumatic conveyors and free falling processes
- For all solid materials from a few kg/h to many t/h
- No armatures inside the pipe and inside flush fitting
- Very fast and contactless measurement
- Easy, quick and cost effective installation and start-up
- Galvanic separated DIN-Rail Transmitter with RS232- and RS485-Interface
- Robust stainless steel version, abrasion and maintenance free
- Limit value monitoring with alarm contact
- Sensor-transmitter distance up to 2000 m
- Easy and quick calibration
- Adjustable sensitivity
- Optional: ATEX for Zone 20 and Zone 2 ☹

## Putting into work

A branch is welded onto the pipe. A 18 mm hole is drilled, the sensor is mounted flush with the inner diameter of the pipe. For commissioning and calibration a notebook with our MF-SMART software needed.

Calibration can be performed with either one or multiple reference flow amounts. The measurement value is output either analog or as digital signal. A serial COM interface is available at the front of the transmitter to connect a notebook computer and a RS485 interface for connection to a PLC system.

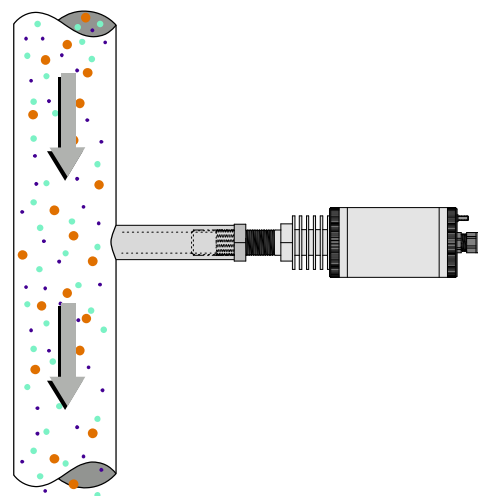

## Application examples of successfully measured products

MF 3000 is measuring in pneumatic transportations and free falling processes. The product's grain size can be between 1 nm and 20mm.

The moisture of the measured material is allowed to be changed up to 12%

<p><b>Materials:</b></p> <p>All dust, powders, granulates, panels, threads etc. Also sticking or abrasive materials</p> <p><b>Industries:</b></p> <p>Animal feed industry          Building materials industry          Cement industry          Chemical industry          Detergent industry          Engineering companies          Food industry          Glass production          Metal production</p>	<p><b>Range of detection:</b></p> <p>from kg/h to many t/h</p> <p>Pharmaceuticals          Pigment production          Plastic industry          Production of ceramics          Production of rubber goods          Production of textiles          Tobacco industry          Washing powder industry</p>
--	--

## Applications



Wood Dust



Jet Material



Plastic Granules



Coal Dust



Fertilizer



Iron -II-Sulfate

### Process Data

#### MF 3000

Measurement start free fall :	Ca. 1 kg/h
Measurement start pneumatic transport	Ca. 1 kg/h
Max. pipe diameter	DN 300
Grain size	1 nm up to 20 mm
Moisture	Depending on the product
Pressure	Up to 6 bar (Option up to 30 bar)
Process temperature	-20 up to +90°C (Option up to +750°C)

### Technical Data Sensor

Medium touched parts	Stainless steel 1.4307 and PA 6.6
Process connecting	Welding flange
Housing material	Stainless steel 1.4307 or ST52
Protection class	IP 65
Power supply	Via transmitter

### Technical Data Transmitter

Construction	DIN-Rail, 22.5 mm
Auxiliary energy	24 V AC/DC
Power consumption	Max. 2W (+ 0.3-8.5W for thermocouple)
Ambient temperature	-10 to +60°C
Protection class	IP 30

### System components



A complete measuring system MF3000 contains the sensor, a cable, a DIN-rail transmitter and the software MF-SMART .

### Sensor

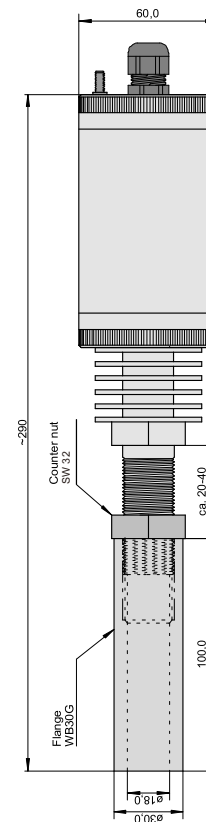

### Transmitter

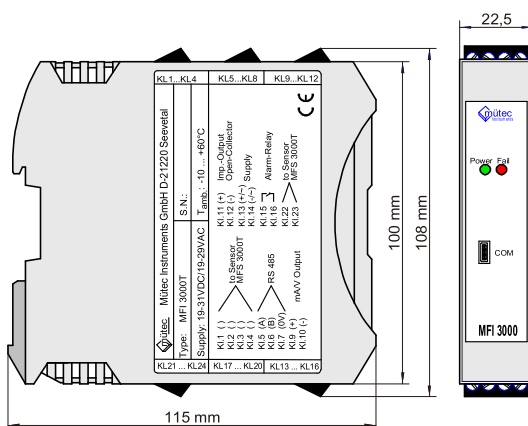

# FS 510M

## Continuous flow monitoring for bulk materials



### Application

The FlowSwitch 510M is monitoring the conveying stream of solids.

Failures and problems during the transport or feeding of powders, dust, pellets or granules can be detected early with this device. This helps prevent serious difficulties that can occur due to clogged piping, material loss, or other technical problems with the system.

### Scope of Use

Animal feed industry	Pharmaceuticals
Building materials industry	Pigment production
Production of ceramics	Power plants
Chemical industry	Production of rubber goods
Detergent industry	Recycling industry
Food industry	Synthetic materials
Glass production	Production of textiles
Metal production	etc.

## Main Benefits

- Reliable, contactless microwave measurement
- For all bulk materials
- Monitors the mass flow in solid handling
- Adjustable sensitivity, damping, hysteresis and filter time
- Easy installation by compact form
- Process connection with welding nozzle

## Function

The measurement procedure of the FlowSwitch 510M is based on the physical principle of the Doppler-Effect.

Therefore the sensor sends out a microwave field. If solids move through this field, the microwaves are reflected and received by the sensor again.

This is converted into a switching process.

All parameters, like sensitivity, damping, filter time and hysteresis are freely adjustable and, can be configured, due to the bargraph, with an exact value. This enables a variable determination of the switching point resp. a switching process for different mass flows.

The installation can be carried out within pipes, on conveying belts, on fall plates, chutes or at similar transport facilities.

The assembly is simply, economical and easy also afterwards possible.

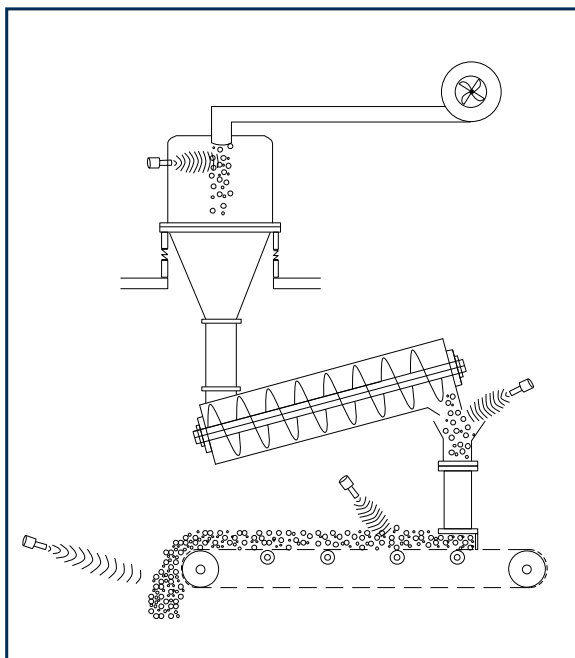

## Technical Data

Housing material	Stainless steel
Sensor surface	Teflon (optional ceramic)
Protection class	IP65
Ambient temperature	-20°C to +60°C
Process temperature	-20°C to +80°C
Process pressure	2 bar (optional 25 bar)
Power supply	24 VDC (18 - 30 VDC)
Current consumption	Ca. 80 mA at 24 VDC
Transmitting power	10 dBm
Output (switching)	Relay contact (change-over contact, potential free)
Switching voltage	35 VAC or 45 VDC
Switching current	min. 10 µA & max. 1 A
Switching power	35 VA or 30 W
Electronic connection	Plug-in screw terminals
Adjustable parameter	Sensitivity, damping, filter, hysteresis, min / max switch
Parameterization	Direct at device via buttons
Indicators	LED green (working) LED yellow (switch) Bargraph (i.a. field intensity)

## FS 510M-F (Option)

- Flange type

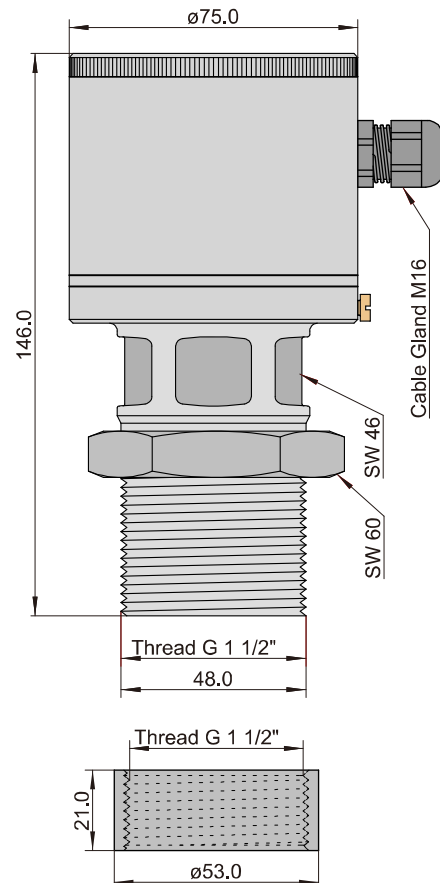

# FS 700E

## Dust monitoring for filter break



### Application

The dust monitor FlowSwitch 700E is used for the detection of filter failure functions e.g. crack or defect in assembling.

By the triboelectric measuring principle a dust breakthrough can be recognized reliable.

### Scope of Use

FlowSwitch 700E can be put in metallic pipes and channels which shall be monitored on dust.

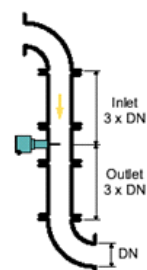

## Main Benefits

- Maintenance free
- Adjustable sensitivity
- Adjustable switch
- Condition indication with LED
- Stainless steel housing
- Compact form
- Easy installation

## Function

The technology is based on a modified triboelectric principle detecting particles interacting with the sensing rod and such particles just passing the rod. Build up on the rod surface will not be detected, only moving particles generate a flow rate proportional signal which is monitored by the electronic.

Installation is done on the clean gas side downstream the filter at a metal duct by welding on of a thread bush boring through the duct wall and screwing in dust watch. On and off distance should this 3-fold of the pipe diameter area, the sensor length 1/3 to 2/3 of the pipe diameter.

The device isn't usable at products, which build an electric conductive coating between sensing rod and pipe wall, caused of abrasion.

## Technical Date

Material	Housing	Stainl. Steel 1.4571
	Sensor rod (standard)	Stainl. Steel 1.4571
Ambient Condition	Isolation (standard)	Polyamide (PA)
	Sealing (standard)	NBR
	temperature	-20°C to +70°C
Process	Protection class	IP 67 (EN 60529)
	EMC	According to EN 61326-1
	Temperature	Max. 90°C
Output	Pressure	Max. 2 bar
	FlowSwitch_01	Max. 48 V AC/DC, 1A Logic high/low switchable
	FlowSwitch_02	Transistor: galvanic isolated Max. 31 V DC, 15 mA Logic high/low switchable
Power supply	FlowSwitch_20	4-20 mA, galvanic isolated, load < 500
	FlowSwitch_01/02	17...31 V DC, max. 60mA.,
	FlowSwitch_20	24 V DC ± 10 %, max. 80 mA
Adjustment	Sensitivity	1...180.000
	Damping	0...10 s
	Switchpoint	1...10
	Zero set	FlowSWITCH_01/02 4 mA, FlowSWITCH_GM20

## Dimensions

(Unit: : mm)

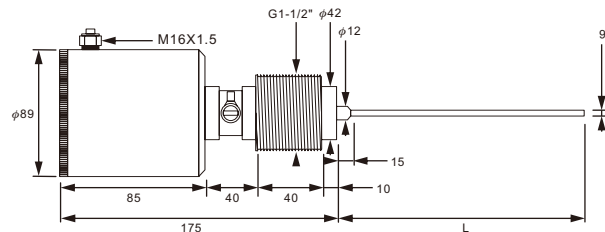

### Indication/ Adjustment elements of output type 01 and 02

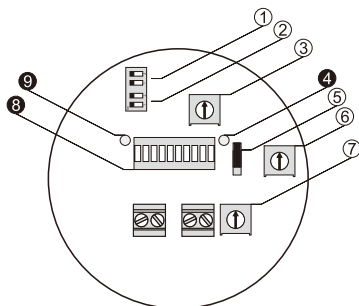

- |                    |                       |                    |  |
|--------------------|-----------------------|--------------------|--|
| Ajustment elements |                       | Indicator elements |  |
| ① sensitivity 1    | ⑤ switching behaviour | ④ alarm            |  |
| ② sensitivity 2    | ⑥ damping             | ⑧ flow rate        |  |
| ③ sensitivity 3    | ⑦ limit value level   | ⑨ power            |  |

### Indication/ Adjustment elements of output type 20

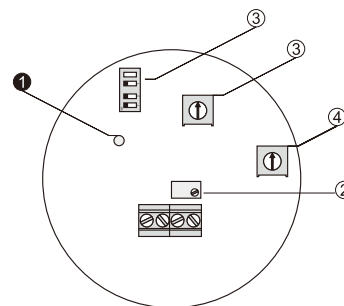

- |                    |  |                     |  |
|--------------------|--|---------------------|--|
| Indicator elements |  | Adjustment elements |  |
| ① power            |  | ② zero adjustment   |  |
|                    |  | ③ span adjustment   |  |
|                    |  | ④ damping           |  |

# FS 710E

## Dust monitoring for filter break

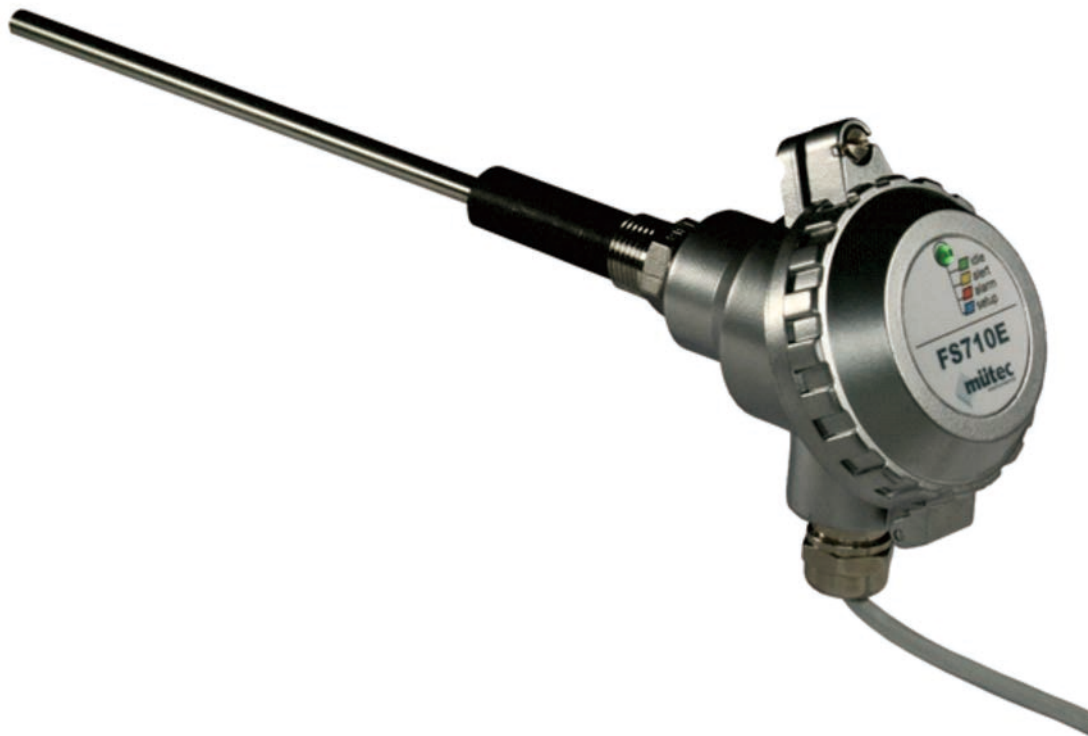

### Application

The dust indicator FS710E is for the use on the clean air side to detect dust behind a filter. In this way, filter cracks, fractures or assembly errors are reported automatically and reliably.

### Scope of Use

FlowSwitch 710E can be put in metallic pipes and channels which shall be monitored on dust

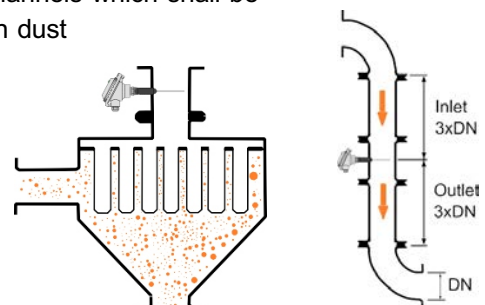

## Function

The measurement system is based on the triboelectric effect: Particles collide permanently with each other or with other materials, e.g. the wall. Because of this process the particles will be charged in a natural way. If these electrically charged particles are flying next to the sensor rod of FS710E or even touch it, the particles are detected via the charge transfer. Resting particles, such as deposits etc., do not affect the measurement. Therefore a subsequent installation into existing exhaust ducts is possible without any problems.

Installation is quick and easy by welding a threaded socket. The sensor rod is inserted into the pipe and fixed by the thread. The sensor rod length should be at least 1/3 of the pipe diameter and must not touch the opposite side.

During operation, the emerging particle load is continuously gathered and classified in three different categories.

	Particle load	Status	LED	Switch output1	Switch output2
<b>Load category I</b>	low	good	green	closed	closed
<b>Load category II</b>	medium	prealarm	yellow	opened	closed
<b>Load category III</b>	high	main	red	closed	opened

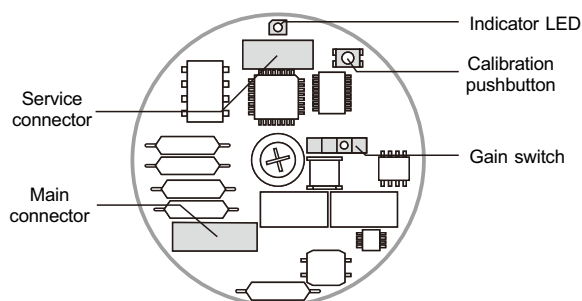

Figure 1 - View of board

Green		Calibration(IN)
White		Calibration(GND)
Yellow		Supply(+24V)
Brown		Supply(0V)
Pink		Solid state relay 1
Red		Solid state relay 1
Grey		Solid state relay 2
Blue		Solid state relay 2

Figure 3 - Wiring

## Main Benefits

- Automatic calibration
- Maintenance free
- Three-condition monitoring
- Two switching points via switching output
- Condition indication by different LED colors
- Compact form
- Protection class IP65
- Easy installation

## Technical Data

Material	Housing	Aluminium
	Sensor rod (standard)	SUS304
	Protection class	IP 65 (EN 60529)
	Isolation (standard)	PPS
Process cond.	Temperature	-20°C to +150°C
	Pressure	0 to 2 bar
Power supply	Voltage	24 VDC
	Power consumption	max. 50 mA
	Power	< 2 W
	Storage	-20°C to +60°C
	EMC	According to EN 61326-1
Output	Switch1 and switch2	
	Switch output	Normally energized
	Switching voltage	60 VAC/DC
	Switching current	Max. 100 mA
Calibration	Switching capacity	6 W
	Precalibration and automatical recalibration	
	Ambient Temp.	-20°C to +50°C*
Other	Storage Temp.	-20°C to +70°C
	Cable	assembled

## Dimensions

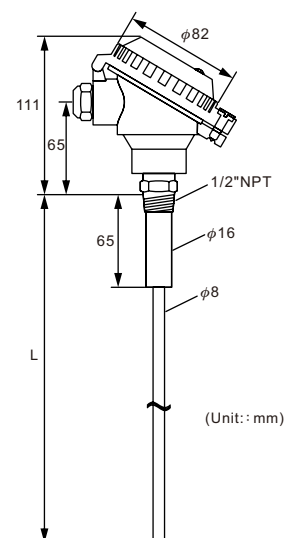

Figure 2 - Dimensions of sensor

# LC 510M

## Contactless level monitoring for bulk material



### Application

The microwave barrier LevelCheck 510M is designed for level monitoring of solids in silos, container, bunkers, shafts, etc.

Furthermore it can be used for: blockage-report, for counting piece goods or for positioning items. The devices are certified up to ATEX Zone 20 and optionally authorized for a process pressure up to 25 bar.

### Scope of Use

Animal feed industry	Pharmaceuticals
Building materials industry	Pigment production
Production of ceramics	Power plants
Chemical industry	Production of rubber goods
Detergent industry	Recycling industry
Food industry	Synthetic materials
Glass production	Production of textiles
Metal production	Etc.

## Main Benefits

- Reliable microwave measuring principle.
- Self-monitoring with additional relay.
- For level monitoring.
- Adjustable sensitivity, damping, hysteresis and filter time.
- Adjustable via 2 key buttons and bargraph.
- Easy installation by compact form.
- Process connection with flange, thread, etc.

## Function

The measurement procedure of the LevelCheck 510M is based on the newest microwave technology. Therefore the sensor sends out a microwave signal. The signal is analyzed by the opposite receiver. Material, which has built up within this field, put a damp on the signal effect. This is converted into a switching process. The measurement is contactless.

Sensitivity, signal damping and hysteresis of the microwave barrier can be adjusted continuously and exactly by use of the bargraph. This enables a variable determination of the switching point resp. a switching process for different process applications. The installation can be carried out within silos, bunkers, pipe systems or at similar transport facilities.

The assembly is simple, economical and easy possible also afterwards.

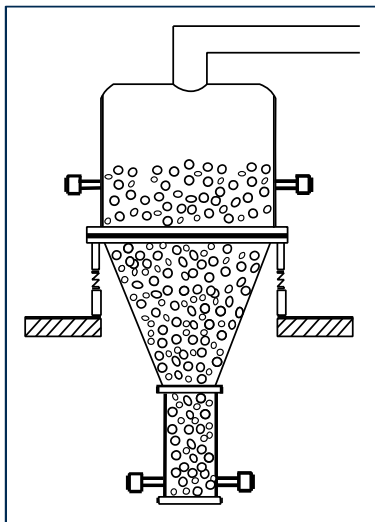

Technical Data	
Housing material	Stainless steel
Sensor surface	Teflon (optional ceramic)
Protection class	IP65
Ambient temperature	-20°C till +60°C
Process temperature	-20°C till +80°C
Process pressure	2 bar (optional 25 bar)
Power supply	18-30 VDC (typical 24 VDC)
Current consumption	Ca. 80 mA at 24 VDC
Transmitting power	10 dBm
Output (switching)	2x Relay output (change-over contact, pot.-free) optional transistor
Switching voltage	45 VDC / 35 VAC
Switching current	Min. 10 µA & max. 1 A
Switching power	30W / 35 VA
Electronic connection	Screw terminals (behind a screw cap with cable gland)
Adjustable parameters	Sensitivity, filter time, hysteresis
Parameterization	via key buttons and switch
Indicators	LED green (power supply) LED orange (switch) Bargraph

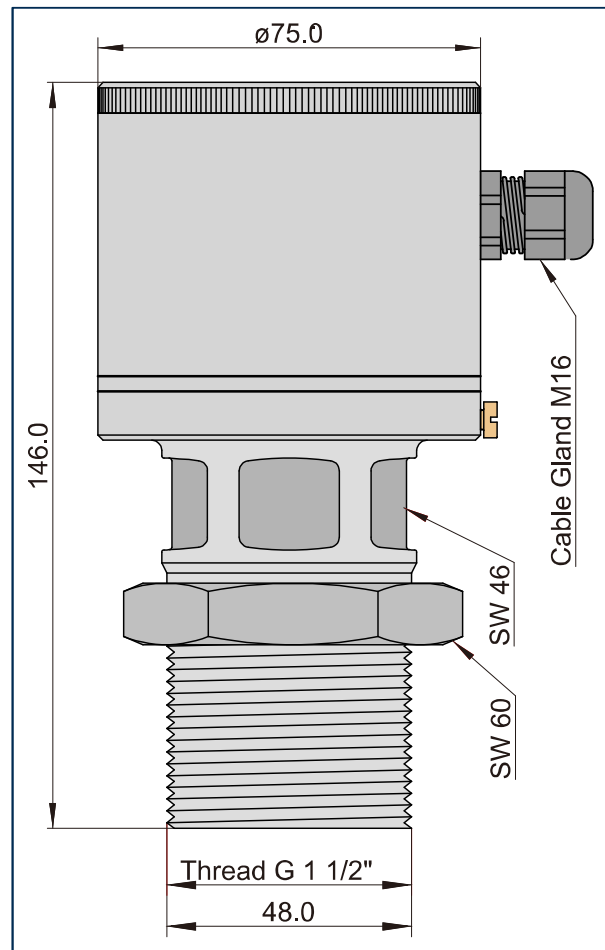

## ORDER INFORMATION

### HUMY3000 ORDER INFORMATION

**HUM 1**     -

**HUMY3000** \_\_\_\_\_

**Model** \_\_\_\_\_  
 00: Standard type      02: Hi-temp. type

**Certification** \_\_\_\_\_  
 00: N/A      B: ATEX-Ex ia      1C: ATEX-Ex d

**Measuring surface material** \_\_\_\_\_  
 17: POM (Standard)      21: PTFE      32: Ceramic

**Cable length** \_\_\_\_\_  
 0003: 3 meters (Standard)  
 0004: 4 meters  
 0005: 5 meters  
 ⋮  
 1000: 1000 meters (Max.)

**Sensor housing** \_\_\_\_\_  
 A: 304L (Standard)      B: 316Ti

**Console** \_\_\_\_\_  
 E: Cabinet type      T: Desktop type      S: Wall mounting type

**Power supply** \_\_\_\_\_  
 F: AC110V(AC110V+DC24V)  
 G: AC220V(AC220V+ DC24V)

### HUMY3019 ORDER INFORMATION

**HUM 2**   **00** -

**HUMY3019** \_\_\_\_\_

**Model** \_\_\_\_\_  
 00: Standard type      02: Hi-temp. type

**Measuring surface material** \_\_\_\_\_  
 17: POM (Standard)      21: PTFE      32: Ceramic

**Cable length** \_\_\_\_\_  
 0003: 3 meters(Standard)  
 0004: 4 meters  
 0005: 5 meters  
 ⋮  
 1000: 1000 meters (Max.)

**Sensor housing** \_\_\_\_\_  
 A: 304L (Standard)      B: 316Ti

**Mounting case** \_\_\_\_\_  
 0: N/A      3: HUMY 3019-3-TR      6: HUMY 3019-6-TR

**Plate Q'ty for controller** \_\_\_\_\_  
 00: N/A  
 01: 1 pc  
 ⋮  
 10: 10 pcs

**Power supply** \_\_\_\_\_  
 F: AC110V(AC110V+DC24V)  
 G: AC220V(AC220V+ DC24V)

## ORDER INFORMATION

### HUMY300 ORDER INFORMATION

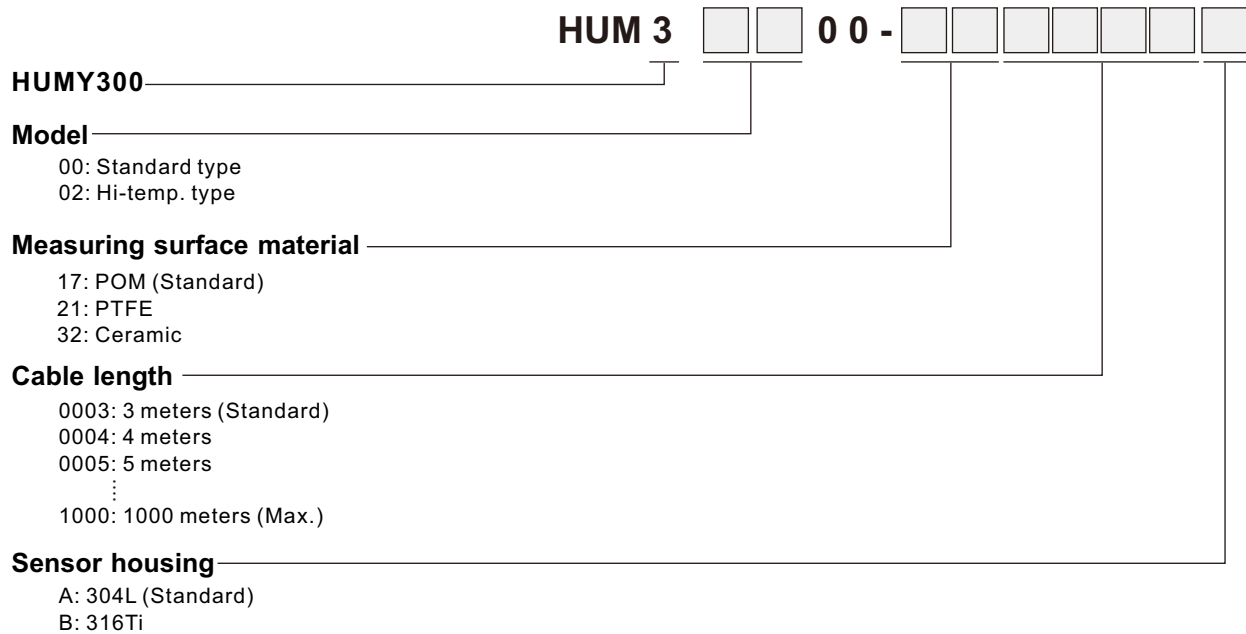

### MF3000 ORDER INFORMATION

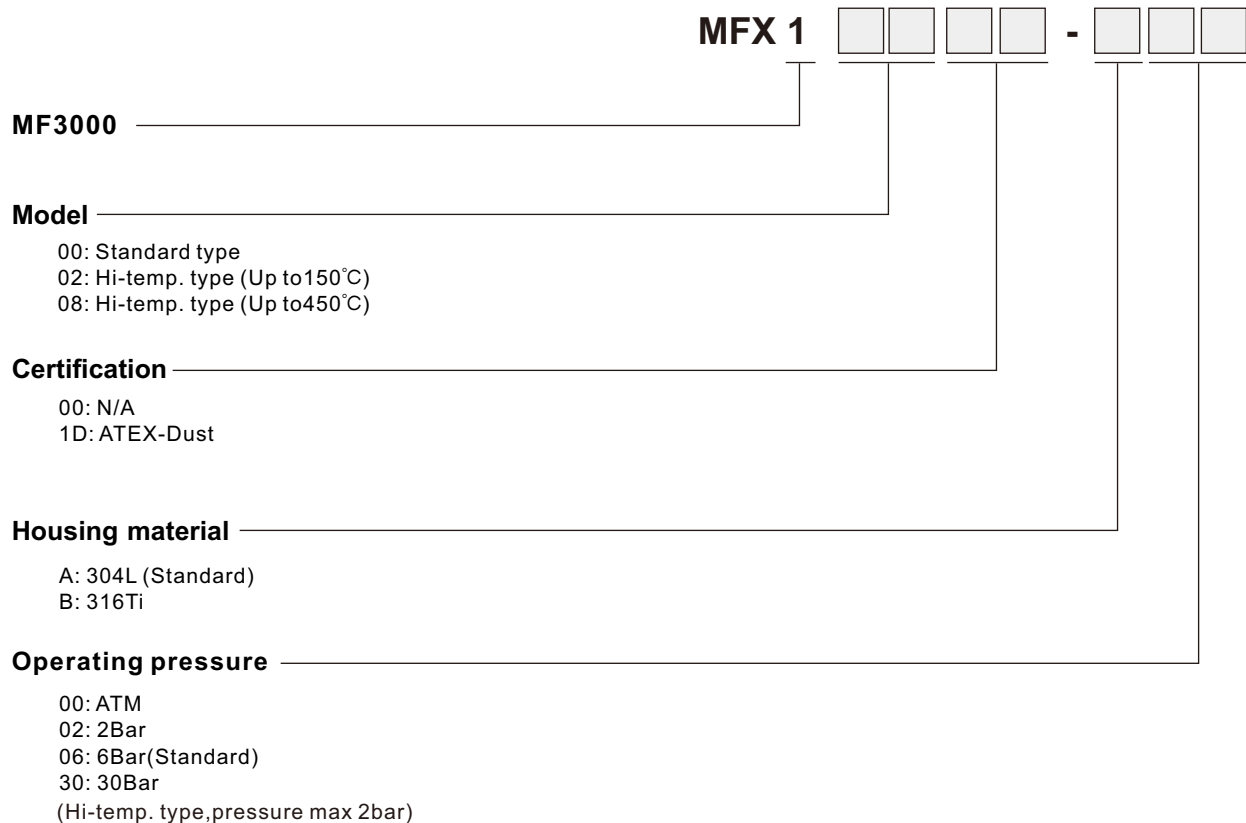

## ORDER INFORMATION

### FS510M ORDER INFORMATION

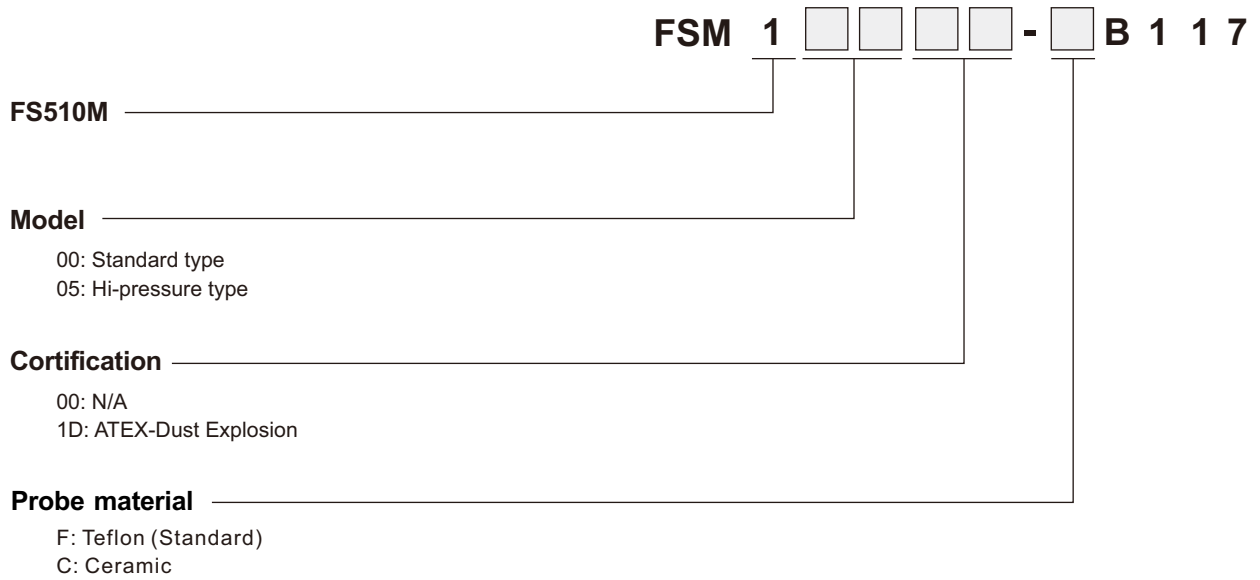

### LC510M ORDER INFORMATION

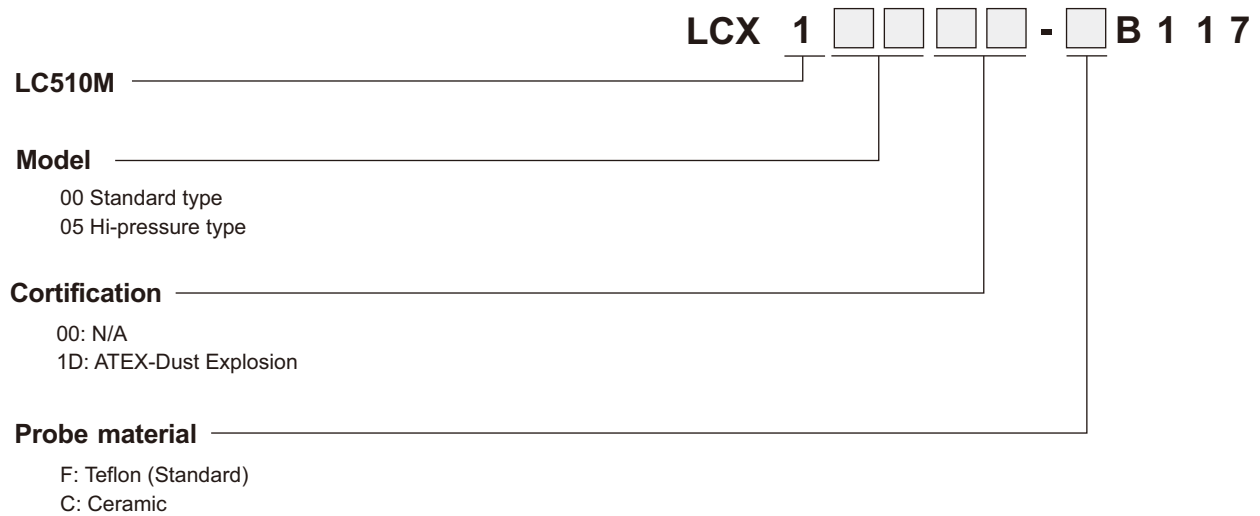

## ORDER INFORMATION

### FS700 ORDER INFORMATION

**FSE 1**     -       **B 1 1 7**

**FS700E** \_\_\_\_\_

**Model** \_\_\_\_\_

- 00: Standard
- 02: Hi-temp. type(Up to 130°C)
- 08: Hi-temp. type(Up to 200°C)
- 09: Hi-temp. type(Up to 290°C)

**Certification** \_\_\_\_\_

- 00: N/A
- 1D: ATEX - Dust Explosion

**Probe length** \_\_\_\_\_

0045: 045mm(Mini)	0400: 400mm
0200: 200mm(Standard)	0800: 800mm(Max.)

**Output** \_\_\_\_\_

04: 4~20mA	28: Transistor Output NPN
26: Relay(Standard)	

**Probe isolated material** \_\_\_\_\_

09: PA(Standard)	13: PEEK(Hi-temperature type only)
------------------	------------------------------------

**material of seals** \_\_\_\_\_

07: NBR(Standard)	25: Silicon(Hi-temperature type only)	44: FPM(ATEX only)
-------------------	---------------------------------------	--------------------

### FS710E ORDER INFORMATION

**FSE 2 0 0**    -       **- A 5**

**FS710E** \_\_\_\_\_

**Certification** \_\_\_\_\_

- 00: N/A
- 1D: ATEX - Dust Explosion

**Probe length(L)** \_\_\_\_\_

0085: 85mm (Min)	0300: 300mm	0500: 500mm (Max.)
0249: 249mm (Standard)	0400: 400mm	

**Process connection** \_\_\_\_\_

- 07: NPT
- 17: G

# Global Network

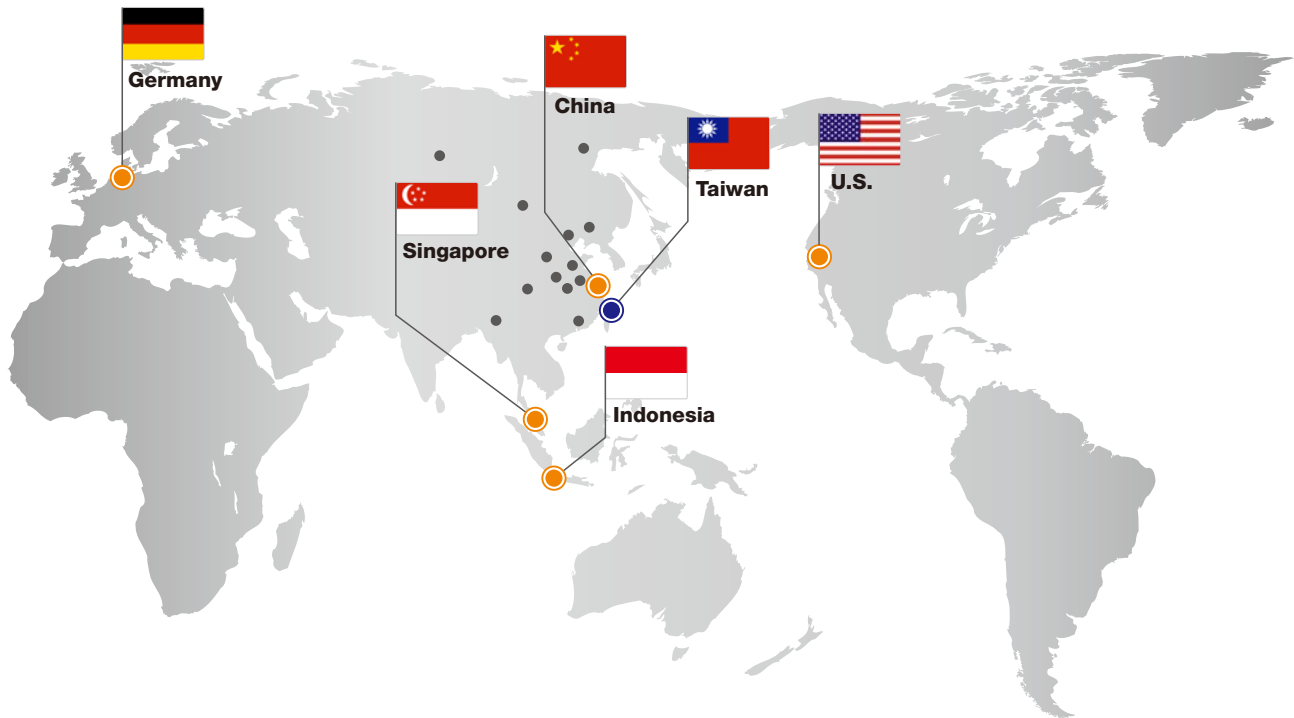

## Head Quarter

### Taiwan

**FineTek Co., Ltd. - Taipei Head Quarter**   
No.16, Tzuchiang St., Tucheng Industrial Park  
New Taipei City 236, Taiwan  
TEL: 886-2-2269-6789  
FAX: 886-2-2268-6682  
EMAIL: info@fine-tek.com

## North America

### California, U.S.

**Aplus Finetek Sensor Inc. - US Office**  
355 S. Lemon Ave, Suite D  
Walnut, CA 91789  
TEL: 1 909 598 2488  
FAX: 1 909 598 3188  
EMAIL: info@aplusfine.com

## Europe

### Germany

**FineTek GmbH - Germany Office**  
Bei den Kämpen 26  
21220 Seevetal-Ramelsloh, Germany  
TEL: +49-(0)4185-8083-12  
FAX: +49-(0)4185-8083-80  
EMAIL: info@fine-tek.de

## Asia

### China

**Fine automation Co., Ltd. - Shanghai Factory**   
No.451 DuHui Rd, MinHang District, Shanghai,  
China 201109  
TEL: 86-21-6490-7260  
EMAIL: info.sh@fine-tek.com

### Singapore

**FineTek Pte Ltd. - Singapore Office**  
37 Kaki Bukit Place, Level 4 Singapore 416215  
TEL: 65-6452-6340  
EMAIL: info.sg@fine-tek.com

### Indonesia

**PT. FineTek Automation Indonesia - Indonesia Office**   
PERGUDANGAN TUNAS BITUNG  
JL. Raya Serang KM. 13,8, Blok C3 No. 12&15, Bitung Cikupa,  
Tangerang 15710  
TEL: 62 (021)-2958-1688  
EMAIL: info.id@fine-tek.com

### Mütec Instruments GmbH - Germany Office

Bei den Kämpen 26  
21220 Seevetal-Ramelsloh, Germany  
TEL: +49-(0)4185-8083-0  
FAX: +49-(0)4185-8083-80  
EMAIL: muetec@muetec.de



經銷商:

# HUMY 3000

## Continuous inline moisture measurement of bulk materials



### Application

The moisture in solids is an important parameter which strongly influences the quality of the product and the efficiency of the production. However, the common measurement method is still the examination of samples in the laboratory, which is time-consuming and the results of which are only available with a delay.

Our inline moisture measurement system HUMY 3000 is the better alternative. It allows immediate reaction to moisture changes, e.g. by regulating a dryer, an automatic humidification system or other process parameters. It is equipped with a local control unit, and can be operated with or without connection to a PLC.

### Scope of use

- Animal food
- Building materials
- Chemical industry
- Coal processing
- Fertilizer industry
- Food industry
- Metal processing
- Pharmaceuticals
- Plastics
- Power plants
- Pulp and Paper
- Recycling
- Steel industry
- Tobacco
- Wood
- etc.



## Technical Data Sensor

Housing material	Stainless steel (1.4301 or 1.4307 as option)
Sensor surface	K = POM C = Ceramic (optional) T = Teflon (optional) S = Ceramic+Teflon (optional)
Ambient temperature	0°C to +70°C (K/C vers.) 0°C to +80°C (T/S vers.)
Process temperature	0°C to +90°C (Non ATEX) 0°C to +120°C (Non-ATEX with high temperature option) 0°C to +70°C (ATEX with K/C) 0°C to +90°C (ATEX with T/S)
Process pressure	6 bar (10 bar temporarily)
Protection class	IP67
Output	RS485 to connect with HUMY/ SCS 3000 control unit
Cable length	Shielded 4-pole cable, 3 meters as standard, any length up to 1000 meters on request
Dimension and weight	D100 mm x 51,5 mm, 1300 g

## Technical Data HUMY 3000

Measured moisture	0-85 % residual moisture or 15-100% dry substance (TR)
Indicator	Percentage value with max. 3 decimal places
Accuracy	Up to 0,1 % (depending on the product)
Average & Filter Value	0 - 999 seconds
Savable Calibration	Up to 24 calibration curves
Data Logger	Storage of moisture and temperature with time and date. 1 GB with 1 s scan rate is enough for 2 years
Ambient temperature	-10°C to +60°C
Protection class	IP20 IP65 (optional)
Supply voltage	115 / 230 VAC with -15 % to +10 %; 24 VDC with +/- 25 %; max. 6 W
Input	1x RS485 (from sensor), 2x digital input (8 – 36 VDC; 2 – 14 mA) 1x external Pt100
Output	2x Analog for moisture & tem- perature (0/4-20 mA; 0-10 V), 2x Relay for max / min alarm (62,5 VA / 30 W, max 125 VAC / 110 VDC, <1A) 2x Transistor for max / min pre-alarm (<1,4 W, <28 VDC, <50 mA) with free configurable delay (0-9,9 sec) and hysteresis (0-99,9 %), NO or NC 1x RS485 with MODBUS protocol, USB via interface cable
Dimension & weight	236 x 132 x 330 mm; 4500 g

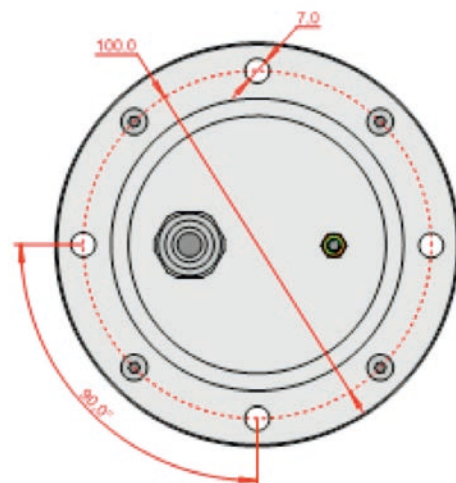
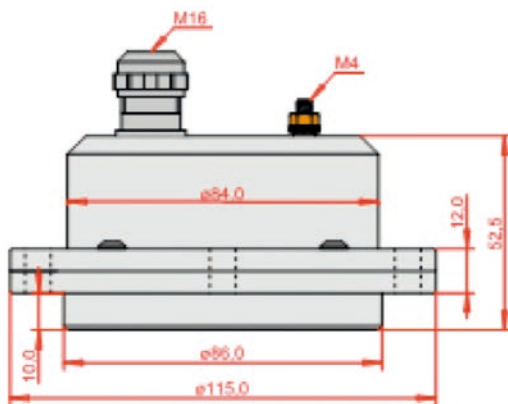





# FlowSwitch FS 510

Continuous flow monitoring  
for bulk materials



**NEW:** ATEX Option



## Application

The FlowSwitch FS 510 is monitoring the conveying stream of solids.

It is a robust microwave-based flow / no-flow switch and detects failures and problems during the transport or feeding of powders, dust, pellets or granules. This helps to prevent serious difficulties that can occur due to clogged piping, material loss, or other technical problems with the conveying system. The compact device can be used wherever monitoring of bulk solids movement is required.

## Scope of use

Animal feed industry  
Building materials  
Cement industry  
Production of ceramics  
Chemical industry  
Coating processes  
Detergent industry  
Food industry  
Foundries  
Glass production  
Lime plants  
Metal production

Minerals  
Pharmaceuticals  
Pigment production  
Plastic manufacturing  
Power plants  
Recycling industry  
Rubber goods  
Synthetic materials  
Textiles  
Wood & Pellets  
etc.

## Main Benefits

- Reliable, contactless microwave measurement
- Works within several meters distance
- Does not interfere with the material
- Very sensitive and flexible with adjustable amplification, filter, hysteresis, delay, min/max
- Compact and easy to install and retrofit
- Wear- and maintenance-free
- Robust stainless steel design
- 100% safe operation with active self-monitoring
- ATEX protection (optional up to zone 20/21)

## Function

The FlowSwitch FS 510 is based on modern microwave technology. If material passes the sensor, the emitted microwaves are reflected. This is converted into a switching process.

The sensor can be installed within pipes, on conveying belts, fall plates, chutes or at similar transport facilities. It allows safe identification of flow / no-flow, inadequate or missing material, plugs, blockage or standstill – from several meters distance. It does not impact the bulk material and is wear- and maintenance-free.

All parameters, like sensitivity, damping, filter time and hysteresis are adjustable, and the sensor can easily be adapted to any use.

The FlowSwitch FS 510 is known as the most robust flow monitor of its class. It is made of stainless steel and optimized for a long lifetime. High ATEX ratings and adapters for high pressure allow use in the most difficult environment.

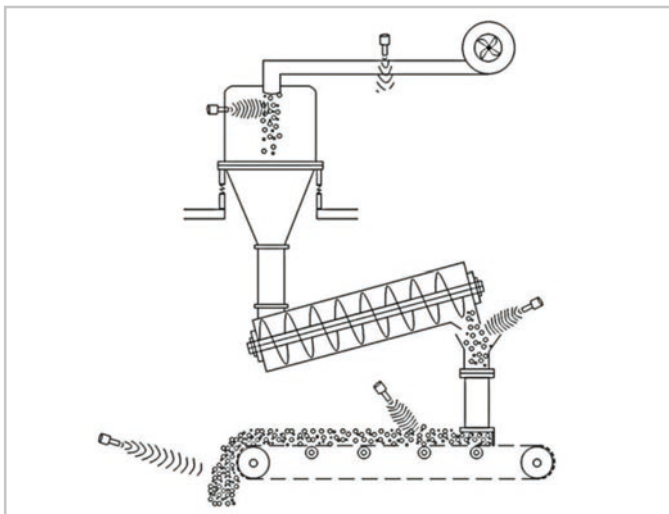

## Technical Data

Housing material	Stainless steel (1.4307)
Sensor surface	Teflon (optional ceramic)
Ambient temperature	-20°C to +60°C
Process temperature	-20°C to +85°C
Process pressure	6 bar (optional 30-60 bar)
Protection class	IP65
Ex protection / ATEX	Optional up to Zone 20/21
Power supply	24 VDC (18 - 30 VDC)
Current consumption	Ca. 80 mA at 24 VDC
Transmitting power	10 dBm
Output (switching)	1x Relay contact (change-over contact, potential free) 1x NO ready contact
Switching voltage	30 VAC or 30 VDC
Switching current	min. 10 µA & max. 2 A
Switching power	30 VA or 30 W
Electr. connection	Plug-in screw terminals
Adjustable parameter	Amplification, filter, hysteresis, delay, min / max switches
Parameterization	Direct at device via buttons
Indicators	LED green (working) LED yellow (switch) Bar graph (e.g. field intensity)

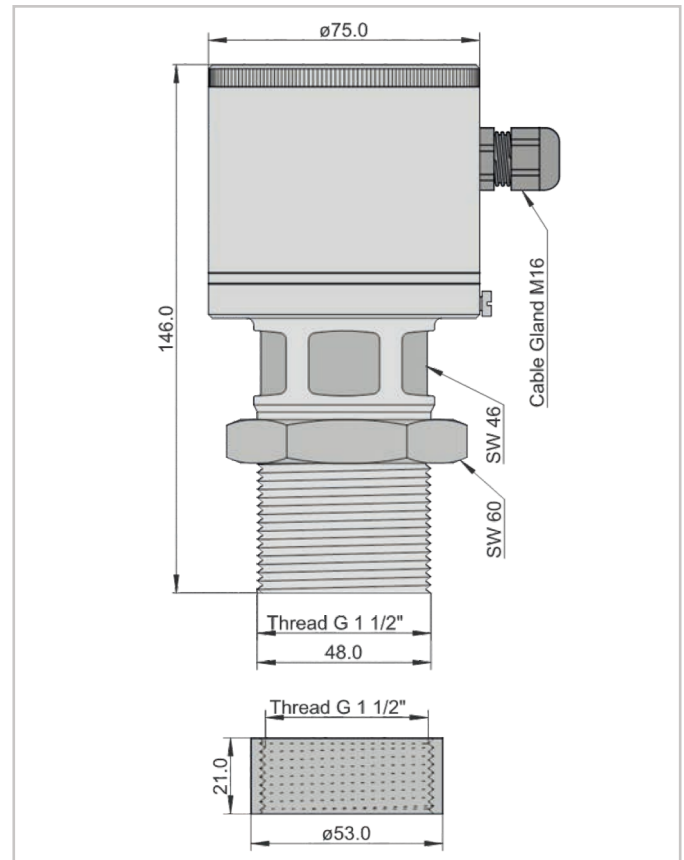

# FlowSwitch FS 700

**Dust monitoring and filter break detection  
adaptable for any application**



## Application

The FlowSwitch FS 700 monitors the dust concentration behind a bag or cartridge filter. It is installed on the clean air side of the filter. It identifies if a filter is damaged, e.g. by cracks, fractures or assembly errors. This allows to replace a damaged or broken filter in time, without losing production time and without polluting the shopfloor or environment.

Dust monitors are especially important in case of heavily contaminated air, recirculation into the factory, strict external emission limits or dust reusage.

The FS 700 is the most flexible device of its class and can be adjusted perfectly to your process. It is available with a relay or analog output, in high temperature versions, as food version and can be adapted for continuous or non-continuous operation.

## Scope of use

Aluminum  
Bakeries  
Building materials  
Cement industry  
Chemical industry  
Fertilizer industry  
Food industry  
Glass production

Mills  
Pharmaceuticals  
Power plants  
Pulp and Paper  
Steel industry  
Surface cleaning  
Wood industry  
etc.

## Main Benefits

- Prevents uncontrolled dust emissions and unnecessary cleaning due to damaged dust filters
- Ensures recircled air is always clean
- Ensures that strict emission limits are fulfilled
- Saves the company from investing into additional police/emergency filters
- Very reactive and fast detection of filter damage
- Is not affected by dust buildup on the rod
- Wear- and maintenance free
- Easy to install into existing air ducts
- Adjustable sensitivity and damping
- Very flexible, can be used for nearly all applications, with multiple options

## Function

The measurement system of the FS 700 is based on the triboelectric effect. Particles collide permanently with each other and are charged in a natural way. If these electrically charged particles are flying next to the sensor rod of the FS 700 or touch it, the particles are detected via a charge transfer. Resting particles, such as deposits etc., do not affect the measurement. An installation into an existing exhaust duct is possible without any problems.

The sensor is available either with a relay or with analog output (4-20 mA). The sensor rod can be individually selected between 45 and 800 mm length. A wide temperature range can be addressed with optional versions for 130°C, 200°C or 290°C process temperature, and ATEX zone 2 and 22 are possible. The sensor material is prepared for use in the food industry. Alternative sensor isolations made out of PA or PTFE and seals out of NBR, FPM or silicone are available. In addition, several settings at the sensor can be adjusted, e.g. for sensitivity and damping.

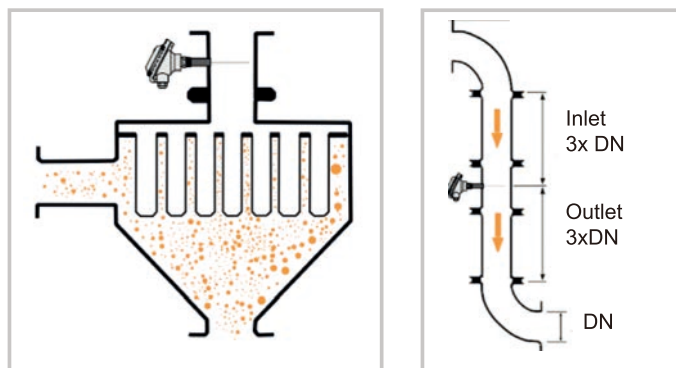

A FS 700 on the clean air side of a filter and in a pipe

To install a FS 700 a threaded socket is welded onto the pipe and a small hole for the sensor rod drilled. The sensor is fixed on the socket. The rod length should be at least 1/3 of the pipe diameter and the rod must not touch the opposite side. The sensor can also be connected with a Tri-clamp adapter. Calibration is done manually and allows to adapt the sensor to any process.

## Technical Data

Housing material	Stainless Steel (1.4571)
Sensor rod	Stainless Steel (1.4571)
Rod length	45-800 mm, customized
Mech.connection	G 0,5" (standard) G 1,5" (high temp. versions)
Tri-clamp Adapter	as option
Ambient temperature	-20°C to +50 / +70°C
Process temperature	-20°C to +90°C 130°C, 200°C, 290°C as option
Process pressure	0 – 6 bar
Protection class	IP65
Ex protection / ATEX	Optional Zone 2 or 22
Power supply	17 – 31 VDC
Current consumption	Max. 60 mA (relay vers.) Max 90 mA (analog vers.)
Output	relay or 4-20 mA
Switching voltage	48 VAC or 48 VDC (relay vers.)
Switching current	Max.1 A (relay vers.)
Output load	<500 Ohm (analog vers.)
Adjust. parameter	Sensitivity, damping
Calibration	Manually
Indicators	LEDs inside of the housing

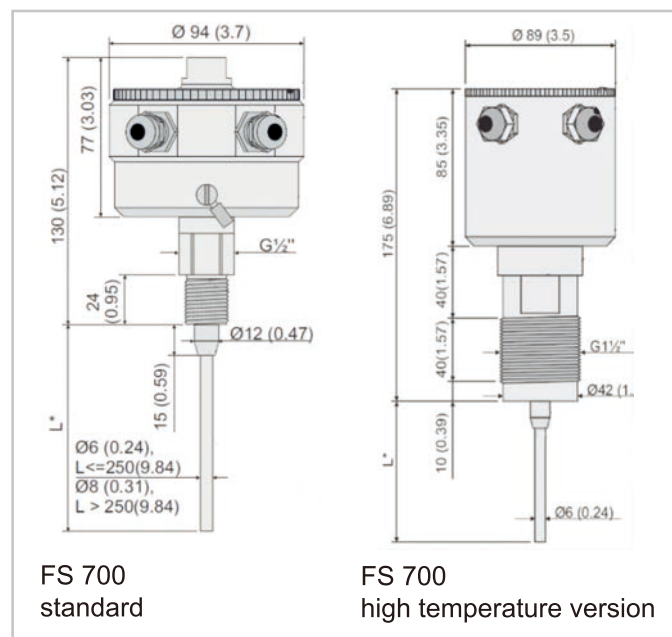

FS 700  
standard

FS 700  
high temperature version

# FlowSwitch FS 710

Dust monitoring  
and filter break detection

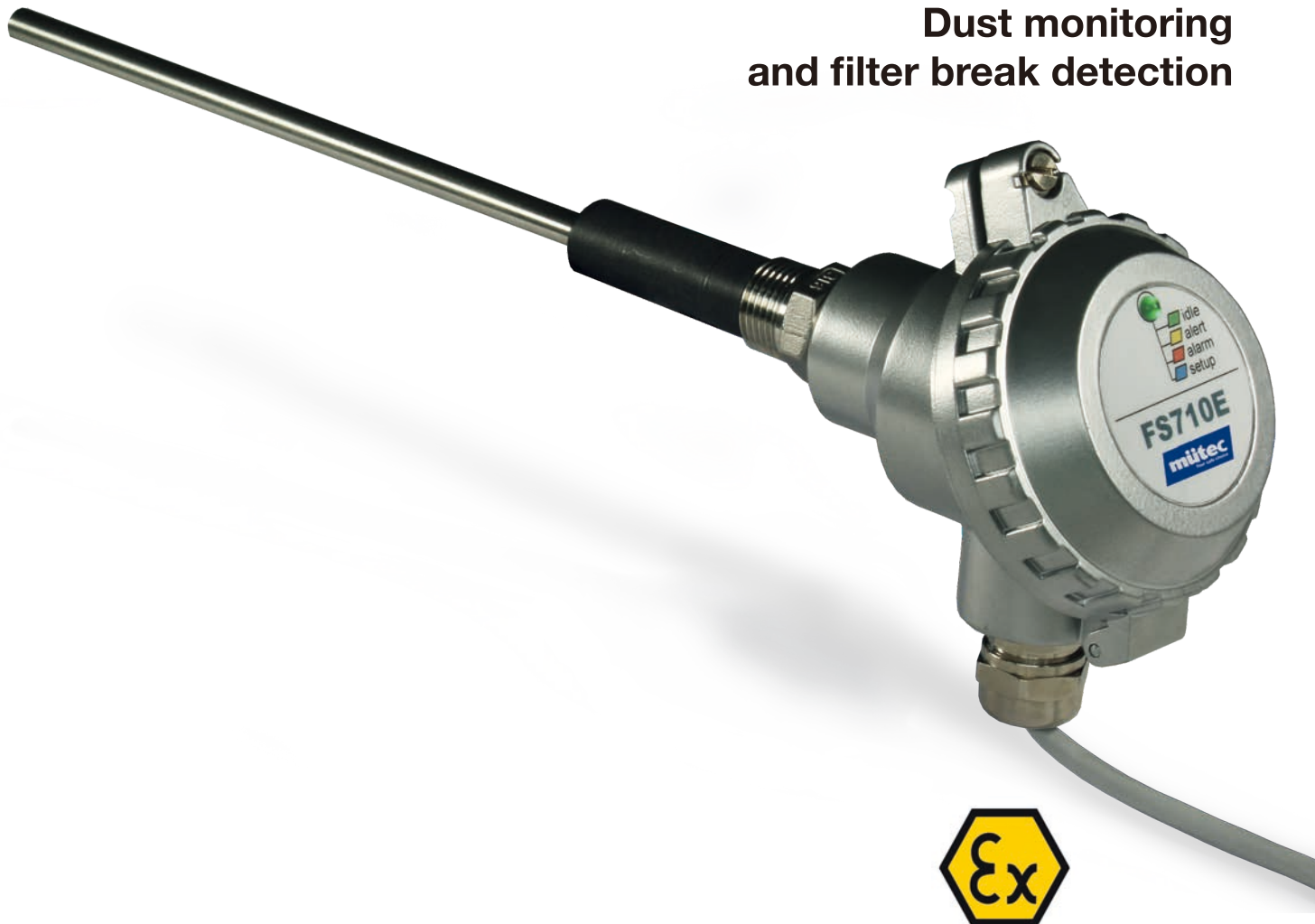

## Application

The FlowSwitch FS 710 monitors the dust concentration behind a bag or cartridge filter. It is installed on the clean air side of the filter. It identifies if a filter is damaged, e.g. by cracks, fractures or assembly errors. This allows to replace a damaged or broken filter in time, without losing production time and without polluting the shopfloor or environment.

Dust monitors are especially important in case of heavily contaminated air, recirculation into the factory, strict external emission limits or dust reusage.

## Scope of use

Aluminum  
Bakeries  
Building materials  
Cement industry  
Chemical industry  
Fertilizer industry  
Food industry  
Glass production  
Mills  
Pharmaceuticals  
Power plants

Pulp and Paper  
Steel industry  
Surface cleaning  
Wood industry

## Main Benefits

- Prevents uncontrolled dust emissions and unnecessary cleaning due to damaged dust filters
- Ensures recircled air is always clean
- Ensures that strict emission limits are fulfilled
- Saves the company from investing into additional police/emergency filters
- Very reactive and fast detection of filter damage
- Is not affected by dust buildup on the rod
- Robust design, well protected for several years of operation in a harsh environment
- Wear- and maintenance free
- Simple automatic calibration
- Easy to install into existing air ducts

## Function

The measurement of the FS 710 is based on the triboelectric effect. Particles collide permanently with each other and are charged in a natural way. If these electrically charged particles are flying next to the sensor rod of the FS710 or touch it, the particles are detected via a charge transfer. Resting particles, such as deposits etc., do not affect the measurement. An installation into an existing exhaust duct is possible without any problems.

The sensor is capable of triggering a pre-alarm when a dust filter is showing first signs of wear, and a main alarm when a filter is broken. Two relays are used to make these signals available. This allows the operator to react in time and prevent an increase in dust emissions and reduce cleaning efforts.

The design of the sensor is optimized for a long lifetime, and the unit is completely free of maintenance. A dedicated ATEX version is available and can be used up to zone 20/21.

To install a FS 710 a threaded socket is welded onto the pipe and a small hole for the sensor rod drilled. The sensor is fixed on the socket. The rod length should be at least 1/3 of the pipe diameter and the rod must not touch the opposite side. Calibration is done in clean air over a measurement period of 10 min. Sensitivity can be adjusted manually. Retrofits into existing ducts are easy and can be done within minutes.

## Technical Data

Housing material	Aluminum
Sensor rod	Stainless Steel (1.4571)
Rod length	250 mm, 500 mm or customized
Mech. connection	NPT 0,5"
Ambient temperature	-20°C to +50°C -10°C to +70°C (ATEX vers.)
Process temperature	-20°C to +150°C -10°C to +180°C (ATEX vers.)
Process pressure	0 – 2 bar 0,8 – 1,1 bar (ATEX vers.)
Protection class	IP65
Ex protection / ATEX	Optional up to Zone 20/21
Power supply	24 VDC
Current consumption	Max. 50 mA, <2W
Output (switching)	2x Relay contacts
Switching voltage	60 VAC or 60 VDC
Switching current	Max. 100 mA
Switching power	6 W
Adjust. parameter	Sensitivity
Calibration	Automatically over 10 min
Indicators	Multi color LED for the dust level (Non-ATEX vers. only)

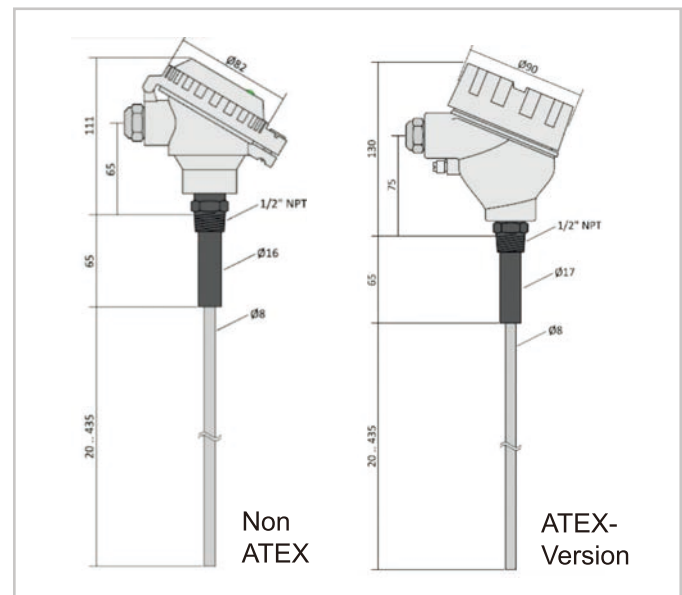
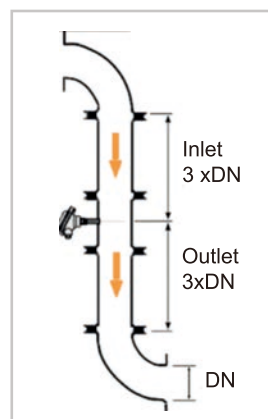
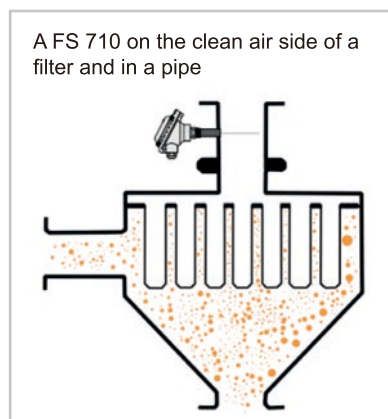

# LevelCheck LC 510

Microwave barrier and contactless level monitoring of bulk materials



**NEW:** ATEX Option



## Application

The microwave barrier LevelCheck LC 510 is designed for level monitoring of solids in silos, container, bunkers, crushers, shafts etc. It can monitor min/max levels, ensure continuous supply and prevent overfilling.

The LevelCheck LC 510 can also be used to detect jamming on conveyor belts, count goods, position items or hedge dangerous areas. The device is robust, easy to install and is not affected by dirt, dust or steam.

## Scope of use

Animal feed industry  
Building materials  
Cement industry  
Ceramics  
Chemical industry  
Detergent industry  
Food industry  
Glass production  
Metal production  
Minerals and mining  
Pharmaceuticals

Pigment production  
Power plants  
Pulp and paper  
Recycling industry  
Synthetic materials  
Textiles  
Waste incineration  
etc.

## Main Benefits

- Reliable, contactless microwave technology
- Up to 25 meters distance between emitter and receiver
- Is not affected by dirt, dust or steam
- Does not interfere with the material
- Very flexible with adjustable amplification, filter, hysteresis and delay
- Compact and easy to install
- Robust stainless steel design
- Wear- and maintenance-free
- 100% safe operation with active self-monitoring
- ATEX protection (optional up to zone 20/21)

## Function

The LevelCheck LC 510 is based on the newest microwave technology. An emitter sends out a low-power microwave beam which is received by an opposite device. The two devices can be placed up to 25 meters apart. Any material between them is detected and a switching process started. This allows e.g. to monitor minimum / maximum fill levels in silos or detect objects entering or leaving the microwave barrier.

The measurement is contact-free and does not impact the bulk material. All settings like amplification, filter, hysteresis, delay can be adjusted, making the system very flexible. Optional versions for ATEX up to zone 20/21 and pressure up to 30-60 bar extend its area of use. The LevelCheck LC 510 is compact and is installed within minutes.

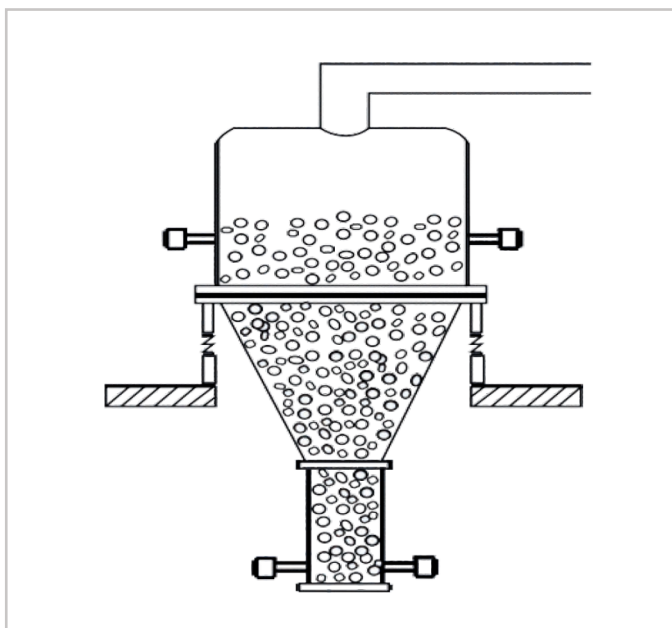

## Technical Data

Housing material	Stainless steel (1.4307)
Sensor surface	Teflon (optional ceramic)
Ambient temperature	-20°C to +60°C
Process temperature	-20°C to +85°C
Process pressure	6 bar (optional 30-60 bar)
Protection class	IP65
Ex protection / ATEX	Optional up to Zone 20/21
Power supply	24 VDC (18 - 30 VDC)
Current consumption	Ca. 80 mA at 24 VDC
Transmitting power	10 dBm
Output (switching)	1x Relay contact (change-over contact, potential free) 1x NO ready contact
Switching voltage	30 VAC or 30 VDC
Switching current	min. 10 µA & max. 2 A
Switching power	30 VA or 30 W
Electr. connection	Plug-in screw terminals
Adjustable parameter	Amplification, filter, hysteresis, delay
Parameterization	Direct at device via buttons
Indicators	LED green (working) LED yellow (switch) Bar graph (e.g. field intensity)

